

Omer W. Blodgett

**AWS – AISC FILLET WELD STUDY**

**LONGITUDINAL AND TRANSVERSE  
SHEAR TESTS**

For

**The American Institute of Steel Construction**

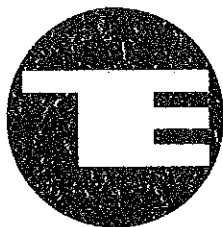

**Testing Engineers Incorporated**

*Materials Testing and Inspection*

SAN JOSE

OAKLAND

SAN DIEGO

LOS ANGELES

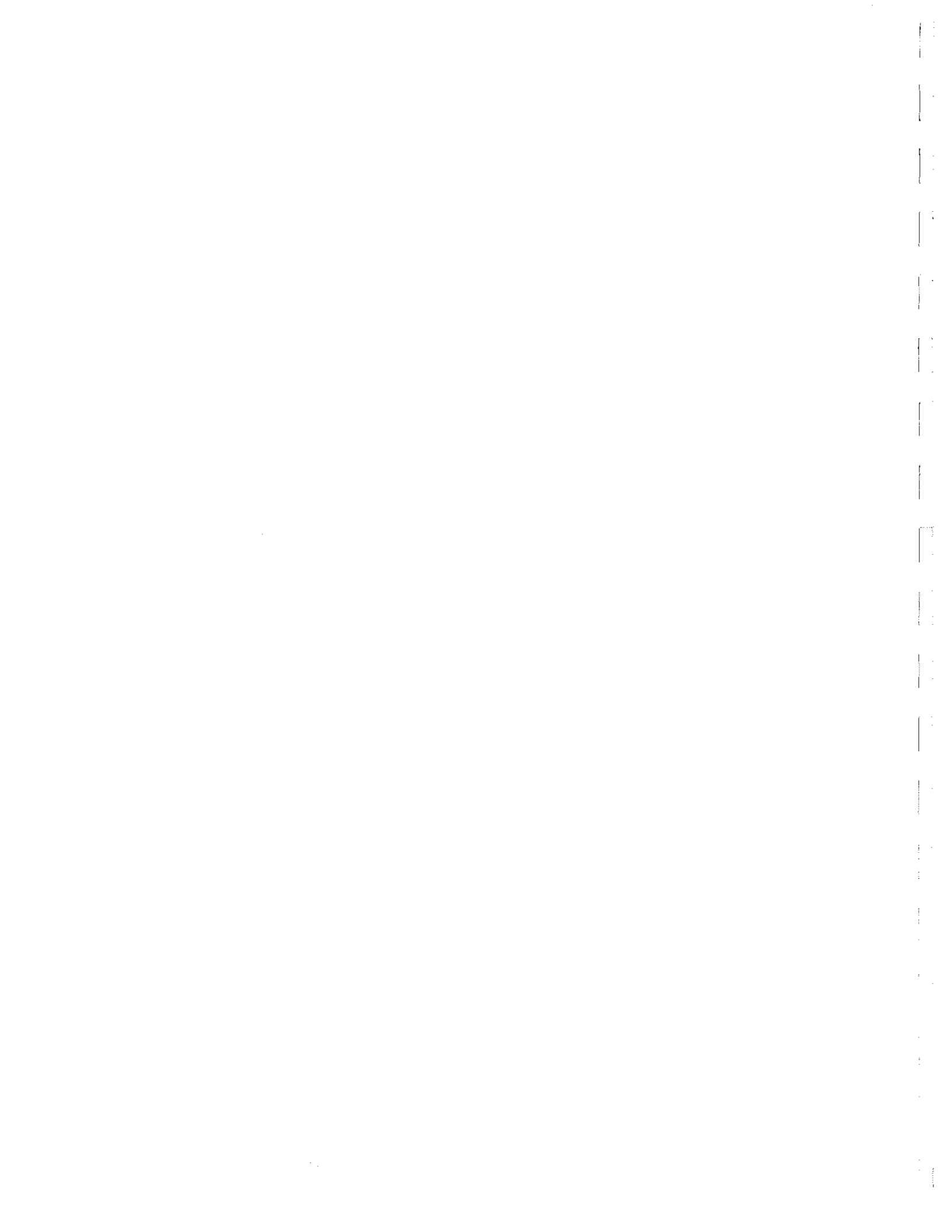

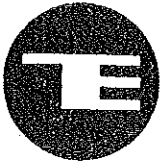

# TESTING ENGINEERS, INCORPORATED

2811 ADELIN ST. OAKLAND, CALIFORNIA 94608 (415) 835-3142

OAKLAND  
SAN JOSE  
LOS ANGELES  
SAN DIEGO

May 31, 1968

American Institute of Steel Construction  
101 Park Avenue  
New York, New York 10017

Attention: Mr. T. R. Higgins

SUBJECT: AWS - AISC Fillet Weld Study

Gentlemen:

In accordance with your letter of authorization dated November 17, 1967, we have completed the fillet weld shear tests as outlined by the Joint AWS-AISC Advisory Task Group on Fillet Welds, Mr. Arsham Amarikian, Chairman.

These tests were conducted in our Oakland Laboratory under the direction of our Chief Metallurgist, Mr. Robert H. Kersten. Engineering supervision and report preparation was by the undersigned.

Also, in response to your verbal request, we have presented herein certain conclusions which in our opinion can be drawn from the results of this test program.

If you have any comments or questions on the conduct of the test or manner of reporting, please feel free to contact us.

Very truly yours,

TESTING ENGINEERS, INCORPORATED

By *F. R. Preece*  
F. R. Preece,  
Structural Engineer

FRP:csh

AWS - AISC FILLET WELD STUDY

LONGITUDINAL AND TRANSVERSE

SHEAR TESTS

REPORT OF TESTS

By

TESTING ENGINEERS, INCORPORATED

For

THE AMERICAN INSTITUTE OF STEEL CONSTRUCTION

## TABLE OF CONTENTS

<u>REPORT OF TESTS</u>	<u>Page</u>
OBJECTIVE .....	1
SCOPE .....	1
Longitudinal and Transverse Shear Tests	
TEST PROCEDURES .....	1
1. Identification	
2. Machining	
3. Testing	
4. Sectioning, Etching and Measuring	
5. Photography	
RESULTS .....	3
1. Measurement of Weld Dimensions	
2. Summary of Calculated Failure Stresses	
DISCUSSION OF RESULTS .....	4
1. Modes of Failure	
2. Dimension of Welds	
3. Strength of Welds	
4. Factors of Safety	
CONCLUSIONS .....	7
 <u>FIGURES, TABLES AND PHOTOGRAPHS</u>	
FIGURE NO. 1 Free body sketch of forces on fillet welds .....	9
FIGURE NO. 2 Statistical variation in fillet weld leg dimension "L" .....	10
FIGURE NO. 3 Average ultimate strength of fillet welds in kips per lineal inch .....	11
FIGURE NO. 4 Average ultimate stress of fillet welds in kips per square inch .....	12
TABLE NO. 1 Schedule of material and electrode combinations and identification numbers (longitudinal) .....	13
TABLE NO. 2 Schedule of material and electrode combinations and identification numbers (transverse) .....	14
TABLE NO. 3 Factors of safety - Longitudinal fillet welds .....	15
TABLE NO. 4 Factors of safety - Transverse fillet welds .....	16
TABLE NO. 5 Summary of calculated stresses - Longitudinal shear ----	17
TABLE NO. 6 Summary of calculated stresses - Transverse shear ----	23
PHOTOGRAPHS 1 through 14 .....	25

TABLE OF CONTENTS (CONTINUED)

<u>TEST DATA</u>	<u>Page</u>
PREPARATION OF SPECIMENS	
a. Longitudinal Fillet Welds	
Drawing D1 Specimen blank before machining -----	39
Drawing D2 Specimen blank after machining -----	40
Drawing D3 Cross Section (for dimensions) -----	41
b. Transverse Fillet Welds	
Drawing D4 Specimen blank before machining -----	42
Drawing D5 Specimen blank after machining -----	43
Drawing D6 Cross Section (for dimensions) -----	44
TABLE NO. 1 -----	45
Schedule of material electrode combinations and identification numbers (for longitudinal fillet welds)	
DATA SHEETS - Longitudinal Fillet Welds -----	46
22 Pages western fabrication	
22 Pages eastern fabrication	
TABLE NO. 2 - Transverse Fillet Weld Tests -----	90
Schedule of material, electrode combinations and identification numbers	
DATA SHEETS - Transverse Fillet Welds -----	91
3 Pages western fabrication	
3 Pages eastern fabrication	
MECHANICAL TESTS -----	97
West coast base metal - 2 pages	
East coast base metal - 2 pages	



# TESTING ENGINEERS, INCORPORATED

2811 ADELIN STREET

OAKLAND, CALIFORNIA 94608

415-838-3142

OAKLAND  
SAN JOSE  
LOS ANGELES  
SAN DIEGO  
EL CENTRO

## AWS - AISC FILLET WELD STUDY

### Longitudinal and Transverse Shear Tests

#### OBJECTIVE

To determine the ultimate strength of fillet welds subjected to longitudinal and transverse shear, the welds being manufactured under shop conditions by two fabricators, one eastern and one western, who were given instructions by the Joint AWS-AISC Task Group as to fabrication and identification of materials.

#### SCOPE

##### Longitudinal Shear Tests

Three test specimens each were tested in three sizes of fillet welds ( $1/4$ ,  $3/8$ , and  $1/2$  inch), four types of electrodes and three base materials from each of two fabricators requiring a total of 132 test specimens as shown in Table No. 1.

##### Transverse Shear Tests

Three  $1/4$ -inch fillet weld test specimens each were tested using three types of electrodes and three basic materials from each of the two fabricators requiring a total of 36 test specimens as shown in Table No. 2.

#### TEST PROCEDURES

##### 1. Identification

All specimens were shipped to our laboratory from the fabricators, prepared in accordance with Drawing D1 for longitudinal shear specimens and D4 for transverse shear specimens. Each specimen was steel-stamped by the fabricator at each end with the appropriate specimen number as shown in Table No. 1 and 2. Heat number of the base material was steel-stamped on the surface of each plate. These heat numbers and

TEST PROCEDURES (CONTINUED)1. Identification (Continued)

corresponding specimen identification numbers were recorded by the inspection agency at the fabricators' shop on specimen data sheets, copies of which are retained in our files.

2. Machining

Upon receipt, sample identification marks were entered in data sheet form and samples were machined in our machine shop as shown on Drawing D2 for longitudinal fillet weld tests and D5 for transverse fillet weld tests. The gage length for each weld was measured and recorded to the closest hundredth of an inch prior to testing.

3. Testing

All weld specimens, longitudinal shear, transverse shear and base metal were tested in tension in accordance with A.S.T.M. A370 Mechanical Testing of Steel Products in our Baldwin 300,000 pound capacity Universal Testing Machine, calibrated in accordance with A.S.T.M. Designation E4-64.

4. Sectioning, Etching and Measuringa. Longitudinal Fillet Welds

An additional transverse saw cut was made across the specimen, cutting all four welds in the remaining unstressed portion. This face was ground, polished and etched with a 20% solution of ammonium persulphate. After etching, the specimen was washed, dried and finally coated with clear plastic. After preparation, vertical and horizontal lines were scribed corresponding to the original plate surfaces as shown in Drawing D3.

Leg size " $L_1$ " (horizontal) and " $L_2$ " (vertical) for all four etched fillet welds were measured and recorded. The actual throat dimension "T", defined as the shortest distance to the face of the weld from the intersection of the original plate surfaces was measured and recorded for all four welds as was the fracture width "W", which is defined as the average



#### 4. Sectioning, Etching and Measuring (Continued)

##### a. Longitudinal Fillet Welds (Continued)

width of the fractured surface for the failed portion of the welds. See Drawing D-3. The distance edge to edge of the saw cuts for each weld was also measured and recorded as the gage length.

All measurements were taken with a machinist scale to the nearest hundredth of an inch. All measurements were later transcribed and included in this report under "Data Sheets - Longitudinal Fillet Welds".

##### b. Transverse Fillet Welds

The ends of each of eight unfailed fillet welds were acid etched as in 4a above. These welds were on the two outside edge pieces that remained after the three shear test specimens were cut from the large specimen plate shown in Drawing D4. All eight welds were measured and recorded to the nearest hundredth of an inch as required in Drawing D6. After fracture of the specimen, the measurements of the two fractured welds were transcribed and presented in this report under "Data Sheets - Transverse Fillet Welds".

#### 5. Photography

Photomicrographs were taken to illustrate the following typical conditions:

Specimens "as-received" and after machining, manner of specimen identification, etched faces of machined sections showing scribed lines for measurement, and typical examples of failure showing weld distortion and failure surface.

### RESULTS

1. Measurements of weld dimensions in inches and failure loads in kips are recorded and reported on data sheets in the Appendix for longitudinal fillet welds, and separately for transverse fillet welds.
2. Summary of calculated failure stresses based on three criteria are reported in Table No. 5 for longitudinal fillet welds and Table No. 6 for transverse fillet welds.

## DISCUSSION OF RESULTS

Three general areas of interest in the results of these tests are developed: mode of failure, dimension of welds, including penetration, and strength of welds.

### Modes of Failure

All specimens failed in the fillet welds. <sup>root</sup>

The longitudinal fillet weld fracture surface typically originated at the root and extended to the inclined surface of the weld at an angle less than  $45^{\circ}$  to the horizontal. Welds displayed high ductility in combined shear and torsional strains. The shearing distortion in some welds was approximately 10% of the length. The surface of failure appeared to be a short series of helical shaped tears. See photos no. 4 through 8 for typical failures. The specimens failed either at two welds on the same side of the splice or alternately in a lapped manner, see photos no. 4 and 5.

The transverse fillet weld fracture surface typically was at a flat angle from the horizontal and appeared to be a clean silky planar break, typically as shown in photo no. 13. Because of joint geometry, large shear distortions could not be measured, however, visual examination revealed a highly ductile failure surface. In practically all cases, the measured distance "W" of the fractured surface exceeded both the throat dimension "T" and the penetration distance "P". In many cases the fracture width "W" was as large as the leg dimension "L".

As an aid to understanding of the types of failure, Figure No. 1 has been included to show the two types of loading and a schematic representation of stresses. It should be noted that higher shear stresses are also present in the transverse fillet welds, and torsional bending stresses are also present in the longitudinal fillet welds.

### Dimensions of Welds

The basic dimensions recorded are as shown in Drawing D3 and D6. The important dimensions for evaluation of fillet weld size however, are the leg dimensions " $L_1$ " and " $L_2$ ". It is noted in the instructions to the fabricator that the specimens were to be positioned for flat welding, in the hope that the leg dimensions " $L_1$ " and " $L_2$ " would be equal. There is some evidence collected to indicate that one shop for some sizes may not have

DISCUSSION OF RESULTS (CONTINUED)Dimension of Welds (Continued)

held strictly to this because the average of the horizontal legs was somewhat larger than the average of the vertical legs.

A statistical study was made of fillet weld leg dimension "L" and is presented herein in Figure No. 2. It is significant that the range for the 3/8" fillet welds considerably lapped over both ranges for the 1/4 inch and 1/2 inch fillets. More significant is that the range for the 1/2" fillet welds extended down to .35 inch and that there were more welds produced measuring 7/16" than either 3/8" or 1/2".

It is noteworthy that for the 1/4" fillet welds the average leg size was 20% over the specified; for 3/8" fillet welds the average leg size was 13% over that specified; and for 1/2" fillet welds the average leg size was only 5% over that specified.

It is also noted that only 15 out of 432 (3-1/2%) were less than the 1/4" specified; that 49 out of 336 (15%) were less than the 3/8" specified; and that 99 out of 288 (34%) were less than the 1/2" specified.

The coefficient of variation "V" and within test variation "V<sub>t</sub>" appear to be reasonable for specimens prepared outside of laboratory control. We have insufficient information on quality evaluation of steel testing in general to rate these adequately.

A review of the data also substantiates previous accepted knowledge that, for these manually welded fillets, the penetration distance "P" seldom exceeds the measured throat "T". This is also shown in the typical photos no. 9 and 14.

Strength of Welds

The concept of strength for fillet welds differs considerably from groove welds which, because of geometry, are merely a continuation of the base metal. Joint configuration and direction of loads make fillet welds much more complicated in state of stress and deformation characteristics. This can be visualized readily by examination of Figure No. 1. The designer of fillet welded joints, however, normally need not concern himself with the state of stress, provided he can use a reasonable assumption as to what forces can be transferred safely from one plane to another. It is convenient to assume these forces are transferred in shear and to set a limit value which is called the

DISCUSSION OF RESULTS (CONTINUED)Strength of Welds (Continued)

allowable shear stress at the theoretical throat dimension of the nominal weld size. Using the allowable shear stress and multiplying it by the theoretical throat dimension, all allowable value can be determined for each size weld expressed in allowable force (kips) per lineal inch of weld.

The present AISC Code permits two values for allowable shear stresses in fillet welds. 13,600 psi is allowed for E60 manual electrodes on all steels or for E70 electrodes with A7 or A373 steels. 15,800 psi is allowed for E70 electrodes used on A36, A242 and A441 steels. The values in kips per lineal inch corresponding to these two criteria are plotted as dotted lines on the lower portion of Figure No. (3).

The average ultimate strength in longitudinal shear also expressed in kips per lineal inch is plotted in Figure No. (3) for the various combinations of electrodes, base material and weld size used in this test program. The values for transverse shear are plotted for the one size fillets tested (1/4"). Inspection of the "Tabulated Summary of Calculated Stresses" will reveal that transverse shear strengths for those combinations tested were from 40 to 70% more than corresponding values in longitudinal shear.

Failure stresses were calculated on the basis of three measured dimensions of the welds, namely the penetration distance "P", the throat dimension "T", and the fractured width "W". All of these calculated stresses are presented in the two sets of tables showing summary of calculated stresses. For comparison, the values for the eastern fabricated specimens are shown next to the values for the western specimens. By inspection, it was determined that the values calculated using fracture width "W" are consistently closer together (east and west) than are the values based on throat dimension or penetration dimension. Also, these are normally the least of the three values. Consequently, these values are plotted on Figure No. (4). The present Code allowable values are not plotted because of scale limitation.

Factors of Safety

Factors of safety were determined by dividing the ultimate shear strength (expressed in kips per lineal inch) by the existing allowable shear value (in kips per lineal inch). Two methods were used to calculate these factors.

## DISCUSSION OF RESULTS (CONTINUED)

### Factors of Safety (Continued)

Method A was based on the average ultimate strength of six specimens.

Method B was based on the minimum individual strength of the six specimens.

Factors of safety for longitudinal fillet welds are presented in Table No. 3 and for transverse fillet welds in Table No. 4.

## CONCLUSIONS

The following tentative conclusions can be reached as a result of this test program:

1. Factors of safety for fillet welds appear to decrease with increasing weld size and do not increase in direct proportion to an increase in specified tensile strength of the materials used.
2. Fillet weld size appears to be more closely related to the weld metal's ability to accommodate large shearing and bending strains rather than its being related to an arbitrary shear stress calculated on theoretical throat dimensions.
3. The larger the size of manual fillet welds, the closer the average measured size is to the specified size and the greater tendency there is for undersize welds.
4. Nevertheless, there appears to be ample room in the present factor of safety for a substantial increase in allowable stresses for fillet welds and to include the new high strength steels and electrodes now available, provided:
  - a. Adequate controls are exercised over dimension profile shape and other quality requirements.
  - b. Proper identification of base metals and electrodes is maintained during fabrication.

CONCLUSIONS (CONTINUED)

5. It is apparent that if higher allowable stresses are permitted for fillet welds, smaller weld sizes would result, and size probably would be governed by the present requirements for minimum weld size as related to thickness of material used. Additional research is needed therefore, to establish a more rational basis for specifying this relationship. The need for such research, however, should not affect present deliberations on increasing allowable stresses.

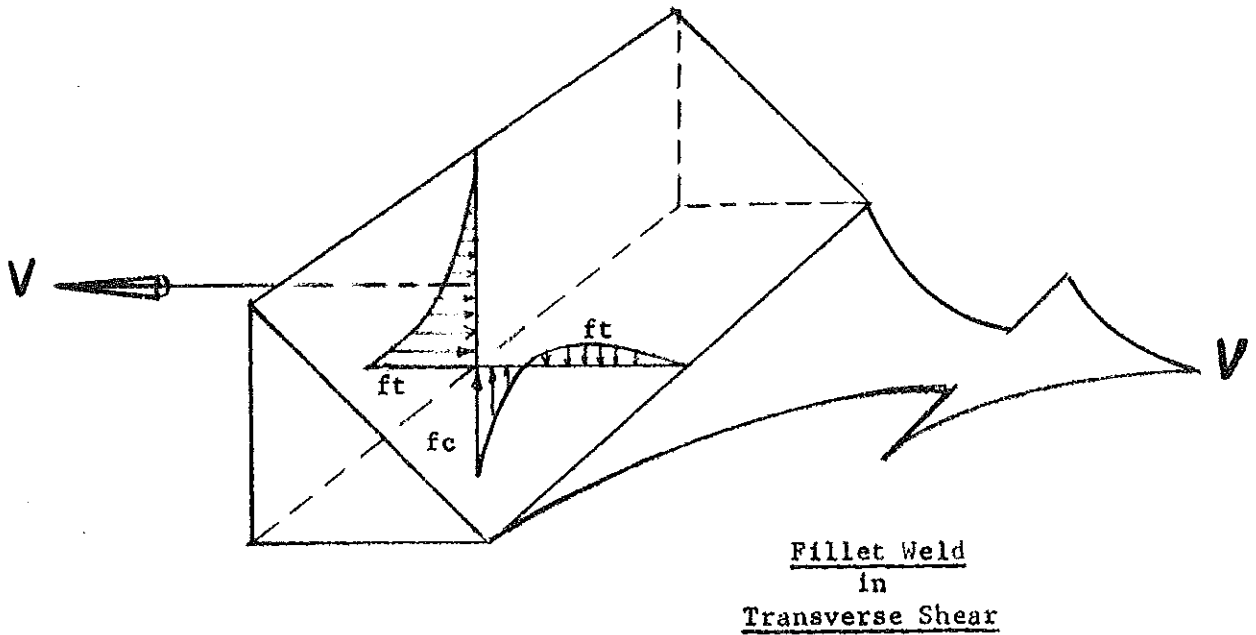
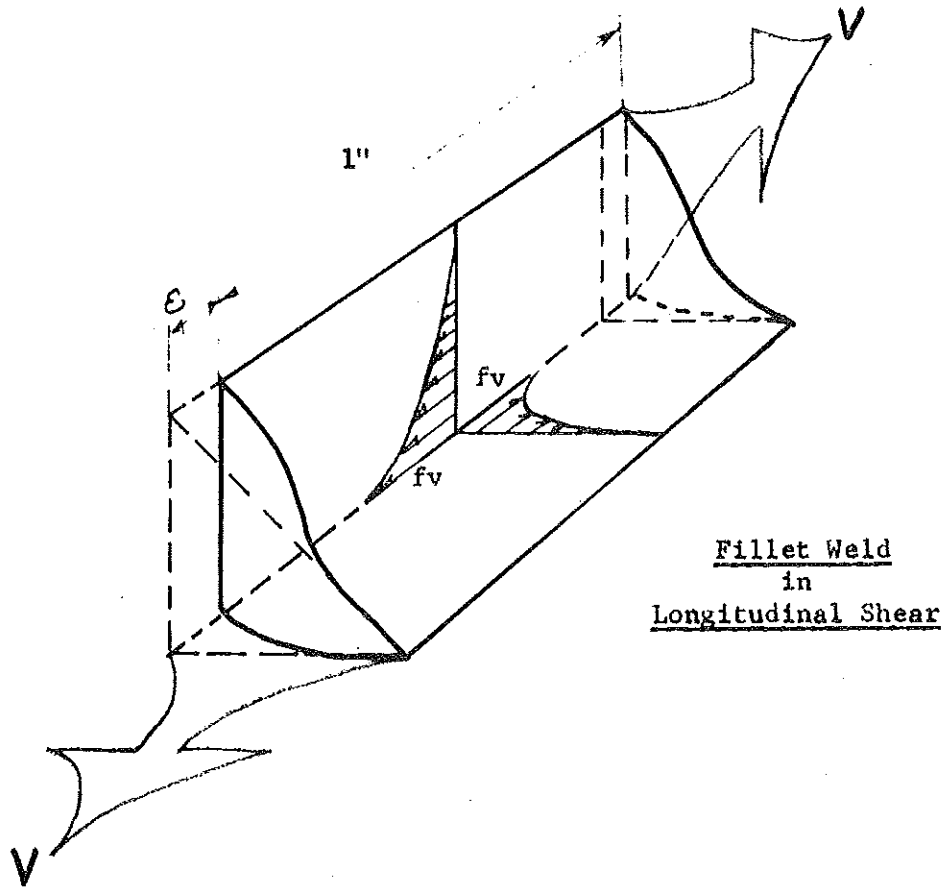
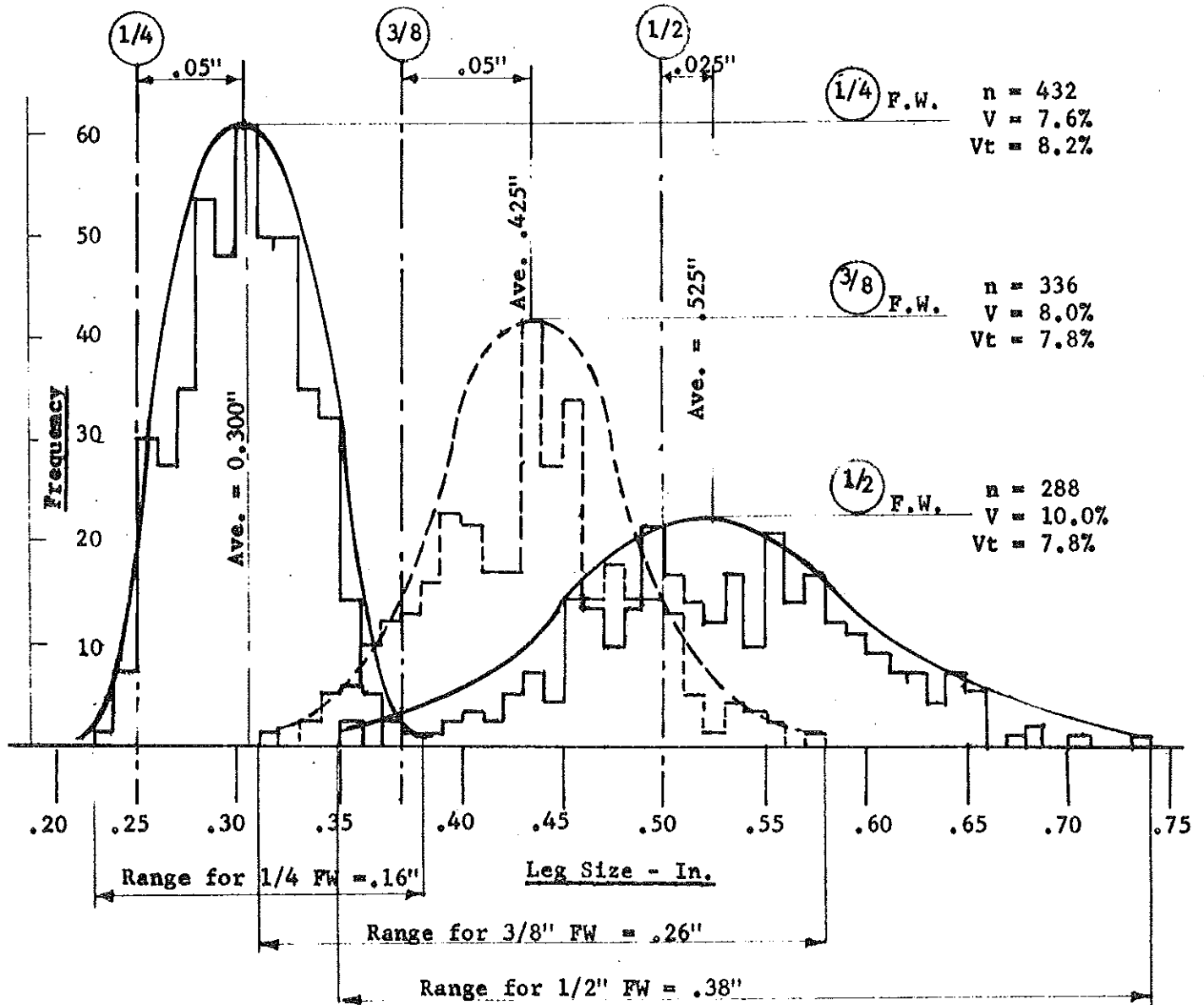

FIGURE NO. 1



STATISTICAL VARIATION

IN

FILLET WELD LEG DIMENSION "L"

Representing a total of 132 samples with 4 measurements of horizontal legs and 4 measurements of vertical legs for each sample - 1056 measurements.

FIGURE NO. 2



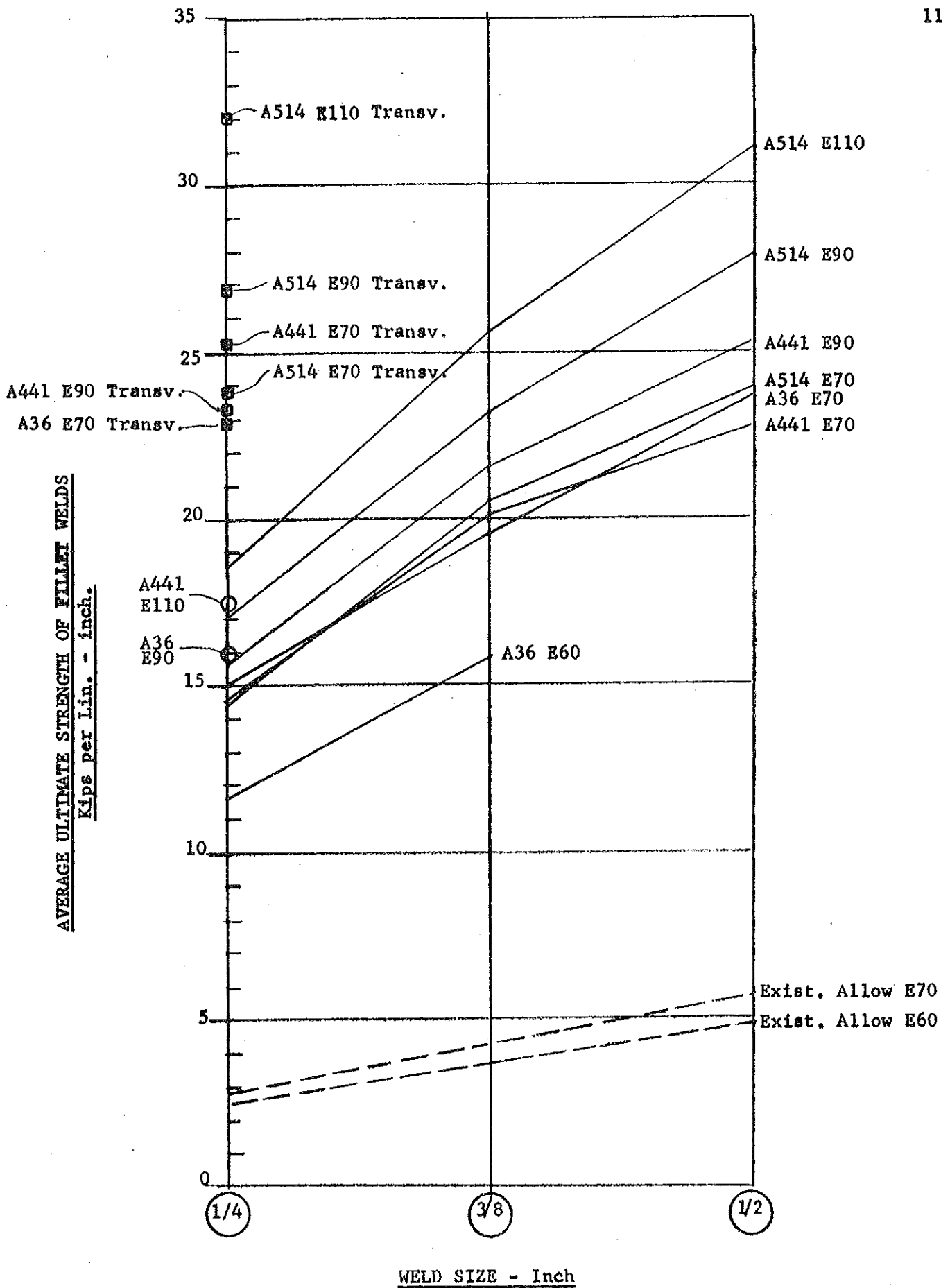
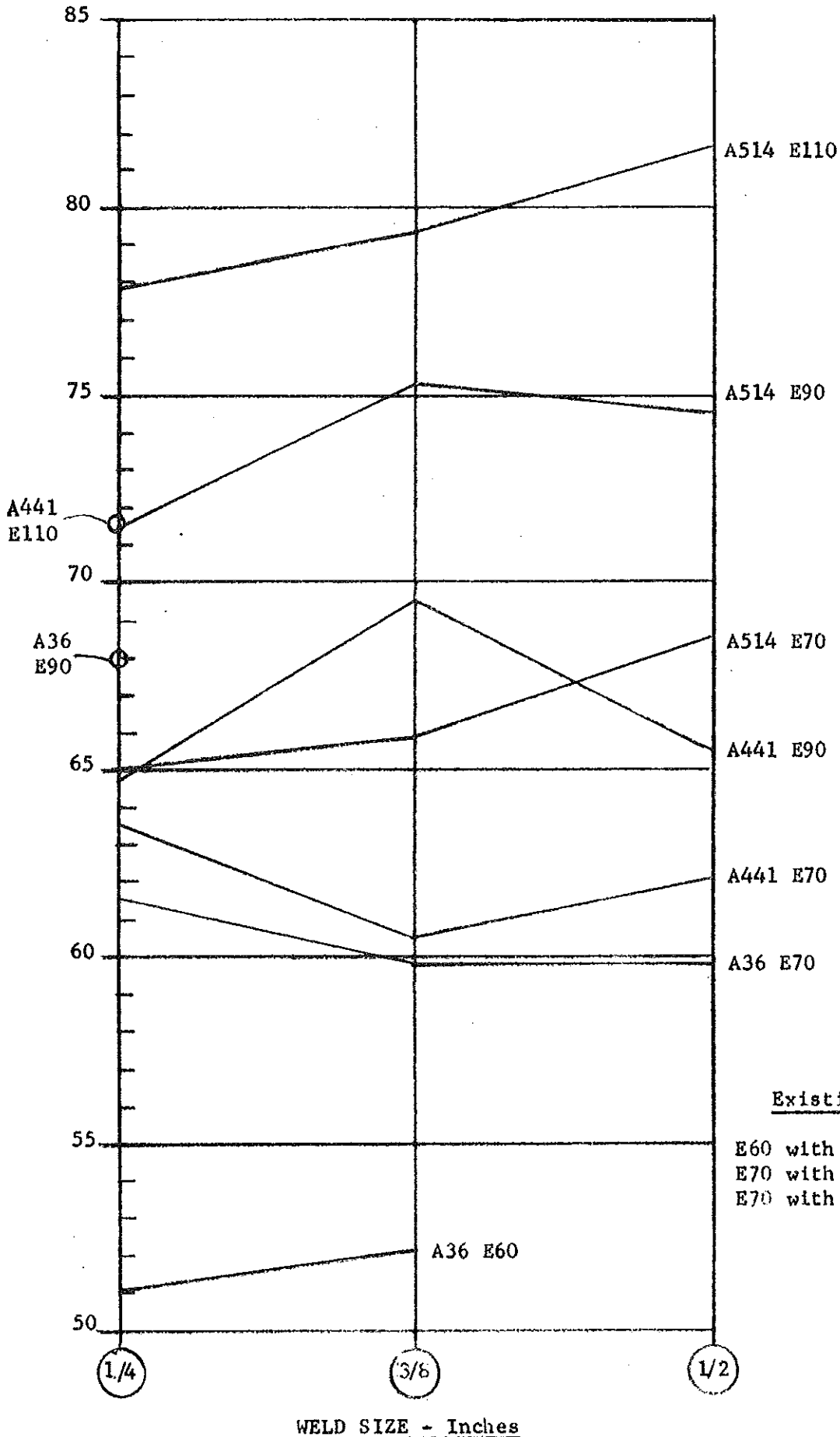

FIGURE NO. 3

TESTING ENGINEERS, INCORPORATED  
Materials Testing and Inspection

Longitudinal Shear

AVERAGE ULTIMATE STRESS in kips per sq. in.  
(Based on measured fracture width)



Existing Code Values

E60 with all steel-13.6 k/psi  
 E70 with A7 & A373-13.6 k/psi  
 E70 with A36, A242 &  
 A441-15.8 k/psi

FIGURE NO. 4

**TABLE I - SCHEDULE OF MATERIAL AND ELECTRODE COMBINATIONS AND IDENTIFICATION NUMBERS**

FABRICATOR	ELECTRODE	E-6012			E-7018			E-9018			E-11018			
		WELD SIZE	BASE METAL	WELD SIZE	BASE METAL	WELD SIZE	BASE METAL	WELD SIZE	BASE METAL	WELD SIZE	BASE METAL	WELD SIZE	BASE METAL	
WEST COAST (W)	A-36	W362A	W363A	W372A	W373A	W374A	W374A	W392A	W493A	W494A	W412A	W513A	W514A	
		W362B	W363B	W372B	W373B	W374B	W374B	W392B	W493B	W494B	W412B	W513B	W514B	
		W362C	W363C	W372C	W373C	W374C	W374C	W392C	W493C	W494C	W412C	W513C	W514C	
	A-441			W472A	W473A	W474A	W474A	W492A	W493A	W494A	W412A	W513A	W514A	
				W472B	W473B	W474B	W474B	W492B	W493B	W494B	W412B	W513B	W514B	
				W472C	W473C	W474C	W474C	W492C	W493C	W494C	W412C	W513C	W514C	
	A-514			W572A	W573A	W574A	W574A	W592A	W593A	W594A	W512A	W513A	W514A	
				W572B	W573B	W574B	W574B	W592B	W593B	W594B	W512B	W513B	W514B	
				W572C	W573C	W574C	W574C	W592C	W593C	W594C	W512C	W513C	W514C	
EAST COAST (E)	A-36													
	A-441													
	A-514													

**NOTE: NO TEST REQUIRED**

**ALL IDENTIFICATION NUMBERS ARE THE SAME AS ABOVE EXCEPT THE FABRICATOR IDENTIFICATION, 'W' IS TO BE REPLACED BY 'E'**

**NOTE - ONLY 1 SPECIMEN REQUIRED OF EACH IDENTIFICATION NUMBER**

**IDENTIFICATION NUMBER KEY**

- 1ST DIGIT - FABRICATOR IDENTIFICATION - "W" OR "E"
- 2ND DIGIT - BASE METAL IDENTIFICATION - 3 = A-36, 4 = A-441, 5 = A-514
- 3RD DIGIT - ELECTRODE TYPE - 7 = E70, 9 = E90, 1 = E110
- 4TH DIGIT - WELD SIZE - 2 = 1/4", 3 = 3/8", 4 = 1/2"
- 5TH DIGIT - SEQUENCE OF SAMPLE PREPARATION FOR EACH TYPE SPECIMEN - A, B, & C

TABLE 2 - TRANSVERSE FILLET WELD TESTS

SCHEDULE OF MATERIAL - ELECTRODE COMBINATIONS  
AND IDENTIFICATION NUMBERS  
ALL WELDS 1/4" FILLET WELDS

FABRICATOR	BASE METAL	ELECTRODE		
		E70	E90	E110
WEST COAST (W)	A-36	TW37A		
		TW37B		
		TW37C		
	A-441	TW47A	TW49A	
		TW47B	TW49B	
		TW47C	TW49C	
	A-514	TW57A	TW59A	TW51A
		TW57B	TW59B	TW51B
		TW57C	TW59C	TW51C
EAST COAST (E)	A-36	TE37A		
		TE37B		
		TE37C		
	A-441	TE47A	TE49A	
		TE47B	TE49B	
		TE47C	TE49C	
	A-514	TE57A	TE59A	TE51A
		TE57B	TE59B	TE51B
		TE57C	TE59C	TE51C

IDENTIFICATION NUMBER KEY

- 1ST DIGIT = (T) MEANS TRANSVERSE WELD TEST
- 2ND DIGIT = FABRICATOR IDENTIFICATION, E OR W
- 3RD DIGIT = BASE METAL IDENTIFICATION 3 = A-36, 4 = A-441, 5 = A-514
- 4TH DIGIT = ELECTRODE IDENTIFICATION, 7 = E70, 9 = E90, 1 = E110
- 5TH DIGIT = SAMPLE NUMBER FOR EACH TYPE OF SPECIMEN

TABLE NO. 3

Factors of Safety Longitudinal Fillet Welds

Based on Existing Code Values 13.6 k/sq. in. for E60  
 15.8 k/sq. in. for all others

<u>Material Combination</u> <u>Base Material &amp; Electrodes</u>		<u>1/4" Fillets</u>		<u>3/8" Fillets</u>		<u>1/2" Fillets</u>	
		<u>A</u>	<u>B</u>	<u>A</u>	<u>B</u>	<u>A</u>	<u>B</u>
A36	E60	4.8	3.6	4.4	3.3	---	---
	E70	5.3	4.0	4.6	3.4	4.2	3.2
	E90	5.8	3.4	5.1	4.4	4.2	3.2
A441	E70	5.3	4.0	4.8	3.6	4.1	3.1
	E90	5.5	3.2	5.2	3.0	4.5	2.6
	E110	5.9	2.8	5.0	5.0	4.3	4.3
A514	E70	5.2	3.9	4.9	3.6	4.2	3.2
	E90	6.1	3.5	5.5	3.2	5.1	2.9
	E110	6.6	3.2	5.3	2.9	5.7	2.7

Notes:

Column A is based on the Average ultimate strength (in kips per lin. inch) for 6 test specimens.

Column B is based on the Minimum ultimate strength (in kips per lin. inch) for 6 test specimens.

Factor of Safety is determined by dividing the ultimate shear strength (in kips/lin.) inch by the allowable shear value (in kips per lin. inch).

From Tbl 5, 
$$\frac{S}{\frac{w(0.707)}{13.6}} = FS$$

$$4.8 = \frac{11.5}{(13.6)(0.25)(0.707)} = FS$$

Handwritten text, possibly a list or notes, located in the upper middle section of the page. The text is faint and difficult to read.

Handwritten text, possibly a signature or a set of notes, located in the lower right section of the page. The text is faint and difficult to read.

TABLE NO. 4

Factors of Safety Transverse Fillet WeldsBased on Existing Code Values - 15.8 k/sq. in.

<u>Material Combination</u> <u>Base Material &amp; Electrode</u>		<u>1/4" Fillets</u>		<u>Minimum</u> <u>B</u>	Average BASED ON 308
		<u>Average</u> <u>A</u>	<u>0.30</u>		
A36	E70	8.2	6.2	7.6	5.8 <del>6.2</del>
A441	E70	9.0	6.8	8.5	6.4 <del>6.8</del>
A514	E70	8.5	<del>(7.8)</del> 6.4	7.2	(7.8) 5.9 <del>6.4</del>
A441	E90	8.4	4.9	6.8	4.0 <del>4.9</del>
A514	E90	9.6	5.6	8.6	5.0 <del>5.6</del>
A514	E110	11.5	5.5	9.7	4.6 <del>5.5</del>

E6012

TABLE 5  
SUMMARY OF CALCULATED STRESS  
LONGITUDINAL FILLET WELDS

SIZE	SPEC. NO.	S <sub>T</sub> K/SQ. IN.*		S <sub>P</sub> K/SQ. IN.*		S <sub>W</sub> K/SQ. IN.*		S K/LIN. IN.*	
		East	West	East	West	East	West	East	West
1/4" A36 E60	362A	68.2	48.1	57.3	49.8	48.5	49.8	13.5	10.6
	B	66.3	48.8	59.4	52.4	51.7	49.9	12.9	10.6
	C	65.6	47.4	56.3	50.2	55.8	52.1	13.9	10.4
Average		66.6	48.0	57.3	50.8	52.0	50.5	13.4	10.5
Av. E.W.		57.3		54.0		51.2		11.5	
3/8" A36 E60	363A	55.4	47.9	55.8	48.2	48.2	54.1	15.9	15.6
	B	55.6	48.2	53.3	48.2	50.1	54.1	16.4	15.7
	C	59.0	50.9	56.8	53.9	54.8	53.0	15.8	16.0
Average		56.6	49.0	54.9	50.1	51.0	53.4	16.0	15.8
Av. E.W.		52.8		52.5		52.2		15.9	
1/4" A36 E70	372A	69.4	65.2	62.9	65.2	59.8	66.0	15.1	14.7
	B	71.0	65.4	65.7	65.4	59.9	63.2	15.3	14.5
	C	68.3	66.4	65.9	66.4	57.2	64.3	14.2	14.8
Average		69.5	65.6	64.8	65.6	58.9	64.4	14.8	15.3
Av. E.W.		67.5		65.2		61.6		15.0	
3/8" A36 E70	373A	64.1	57.8	60.3	60.2	57.0	62.7	20.4	18.4
	B	63.1	62.8	58.0	66.7	51.3	65.6	19.9	18.8
	C	63.8	61.5	60.5	61.5	56.4	66.9	20.6	18.9
Average		63.6	60.6	59.5	62.8	54.8	65.0	20.3	18.7
Av. E.W.		62.1		61.2		59.9		19.5	

\*NOTES

S<sub>T</sub> K/Sq. In. — ultimate stress based on measured throat dimension T

S<sub>P</sub> K/Sq. In. — ultimate stress based on measured penetration P

S<sub>W</sub> K/Sq. In. — ultimate stress based on measured fracture width W

S<sub>K</sub> K/Lin. In. — total failure load divided by total weld length

See Drawing D-3 for location of symbols T, P and W.



TABLE 5 (CONT.)  
SUMMARY OF CALCULATED STRESS

LONGITUDINAL FILLET WELDS

SIZE	SPEC. NO.	S <sub>T</sub> K/SQ. IN.*		S <sub>P</sub> K/SQ. IN.*		S <sub>W</sub> K/SQ. IN.*		S K/LIN. IN.*	
		East	West	East	West	East	West	East	West
1/2" A36 E70	374A	64.4	60.8	55.9	60.8	59.1	60.8	23.5	23.4
	B	65.4	60.8	57.1	61.2	58.5	62.4	23.7	23.4
	C	62.3	59.9	56.9	61.1	56.3	61.9	24.6	23.4
Average		64.0	60.5	56.6	61.0	57.9	61.7	23.9	23.4
Av. E.W.		62.3		59.4		59.8		23.6	
1/4" A36 E90	392A	74.4	65.1	61.3	67.3	59.5	68.8	15.6	15.0
	B	74.3	79.0	65.0	81.0	62.6	74.5	16.9	16.4
	C	77.9	67.2	69.8	73.4	65.0	70.2	16.8	15.8
Average		75.7	70.4	65.4	73.9	62.4	71.2	16.4	15.8
Av. E.W.		73.0		69.6		68.0 <sup>66.8</sup>		16.1	
1/4" A441 E70	472A	74.7	57.8	69.6	56.7	60.2	67.9	15.5	14.6
	B	73.4	61.1	67.7	61.1	59.8	67.9	15.2	13.9
	C	68.8	63.4	64.6	62.7	61.4	63.4	15.6	14.4
Average		72.3	60.8	67.3	60.2	60.5	66.4	15.4	14.3
Av. E.W.		66.5		63.8		63.5		14.8	
3/8" A441 E70	473A	66.5	63.8	65.5	65.4	59.6	64.3	21.8	19.3
	B	70.4	60.4	60.5	61.4	56.1	61.9	21.5	18.4
	C	68.2	57.0	60.3	59.8	59.9	61.7	22.2	18.7
Average		68.4	60.4	62.1	62.2	58.5	62.6	21.5	18.8
Av. E.W.		64.4		62.2		60.5		20.2	

\*NOTES

S<sub>T</sub> K/Sq. In. — ultimate stress based on measured throat dimension T

S<sub>P</sub> K/Sq. In. — ultimate stress based on measured penetration P

S<sub>W</sub> K/Sq. In. — ultimate stress based on measured fracture width W

S<sub>K</sub> K/Lin. In. — total failure load divided by total weld length

See Drawing D-3 for location of symbols T, P and W.

TABLE 5 (CONT.)  
SUMMARY OF CALCULATED STRESS

LONGITUDINAL FILLET WELDS

SIZE	SPEC NO.	S <sub>T</sub> K/SQ. IN.*		S <sub>P</sub> K/SQ. IN.*		S <sub>W</sub> K/SQ. IN.*		S K/LIN. IN.*	
		East	West	East	West	East	West	East	West
1/2" A441 E70	474A	64.6	54.9	58.1	55.9	59.1	63.0	24.2	21.3
	B	65.5	58.5	57.8	57.4	58.4	65.6	24.6	21.8
	C	62.1	58.5	59.0	60.1	59.4	64.2	23.9	21.3
Average		64.1	57.3	58.3	57.8	58.9	64.3	24.2	21.5
Av. E.W.		60.7		58.0		62.1		22.8	
1/4" A441 E90	492A	79.0	63.7	68.2	65.3	62.7	67.0	17.6	13.1
	B	76.5	69.4	65.4	68.6	63.5	74.7	16.8	14.6
	C	85.8	65.9	75.1	67.5	61.8	70.0	16.5	14.2
Average		80.4	66.3	69.6	67.1	62.7	70.6	16.9	14.0
Av. E.W.		73.3		68.3		64.7 <i>66.6</i>		15.5	
3/8" A441 E90	493A	82.9	67.9	68.6	69.6	67.6	72.6	22.0	21.2
	B	83.9	74.2	69.3	73.3	65.6	75.3	21.8	22.6
	C	73.0	71.5	66.3	71.5	65.8	71.5	21.5	20.8
Average		79.6	71.2	68.1	71.5	66.3	73.1	21.8	21.5
Av. E.W.		75.4		69.6		69.7		21.7	
1/2" A441 E90	494A	81.5	66.9	70.9	67.8	61.2	70.7	25.9	25.1
	B	79.9	67.4	65.2	67.4	60.2	71.3	25.6	24.8
	C	82.0	64.0	65.5	64.0	59.2	69.5	26.0	24.3
Average		81.1	66.1	67.2	66.4	60.2	70.5	25.8	24.7
Av. E.W.		73.6		66.8		65.4		25.2	

\* NOTES

S<sub>T</sub> K/Sq. In. – ultimate stress based on measured throat dimension T

S<sub>P</sub> K/Sq. In. – ultimate stress based on measured penetration P

S<sub>W</sub> K/Sq. In. – ultimate stress based on measured fracture width W

S<sub>K</sub> K/Lin. In. – total failure load divided by total weld length

See Drawing D-3 for location of symbols T, P and W.

TABLE 5 (CONT.)  
SUMMARY OF CALCULATED STRESS

LONGITUDINAL FILLET WELDS

SIZE	SPEC. NO.	S <sub>T</sub> K/SQ. IN.*		S <sub>P</sub> K/SQ. IN.*		S <sub>W</sub> K/SQ. IN.*		S K/LIN. IN.*	
		East	West	East	West	East	West	East	West
1/4" A441 E110	412A	83.4	63.7	76.7	65.4	70.9	64.5	19.0	12.4
	B	88.4	69.2	85.4	77.4	72.9	70.9	18.8	14.7
	C	96.3	76.6	77.2	78.6	71.5	77.6	19.5	15.3
Average		89.4	69.8	79.8	73.8	71.8	71.0	19.1	14.1
Av. E.W.		79.6		76.8		71.4		16.6	
1/4" A514 E70	572A	73.4	70.2	71.7	72.2	63.2	64.9	16.0	12.8
	B	82.1	66.6	77.4	66.6	66.7	64.2	16.8	13.0
	C	75.2	70.0	73.4	75.1	64.4	66.3	15.8	12.8
Average		76.9	68.9	74.2	71.3	64.8	65.1	16.2	12.9
Av. E.W.		72.9		72.8		65.0		14.5	
3/8" A514 E70	573A	81.1	61.7	74.5	63.3	65.2	66.6	20.7	19.1
	B	77.7	62.2	68.7	60.4	60.2	70.7	20.8	20.8
	C	75.8	61.7	71.2	61.2	62.6	70.0	20.7	20.8
Average		78.2	61.9	71.5	61.6	62.7	69.1	20.7	20.2
Av. E.W.		70.0		66.6		65.9		20.4	
1/2" A514 E70	574A	70.6	63.5	69.2	64.0	69.6	71.7	25.9	22.2
	B	74.6	64.7	68.4	63.2	71.1	68.8	26.5	21.7
	C	64.8	62.6	60.0	62.6	63.1	68.3	24.4	22.5
Average		70.0	63.6	65.9	63.2	67.9	69.6	25.6	22.1
Av. E.W.		66.8		64.6		68.6		23.8	

\* NOTES

S<sub>T</sub> K/Sq. In. — ultimate stress based on measured throat dimension T

S<sub>P</sub> K/Sq. In. — ultimate stress based on measured penetration P

S<sub>W</sub> K/Sq. In. — ultimate stress based on measured fracture width W

S<sub>K</sub> K/Lin. In. — total failure load divided by total weld length

See Drawing D-3 for location of symbols T, P and W.

TABLE 5 (CONT.)  
SUMMARY OF CALCULATED STRESS

LONGITUDINAL FILLET WELDS

SIZE	SPEC NO.	S <sub>T</sub> K/SQ. IN.*		S <sub>P</sub> K/SQ. IN.*		S <sub>W</sub> K/SQ. IN.*		S K/LIN. IN.*	
		East	West	East	West	East	West	East	West
1/4" A514 E90	592A	88.6	79.6	82.0	79.6	68.8	73.7	19.3	14.9
	B	89.8	75.6	82.7	73.8	66.3	78.5	18.4	15.1
	C	86.2	75.0	79.1	73.2	72.3	72.3	19.0	15.0
Average		88.2	76.7	81.3	75.5	69.1	73.8	18.9	15.0
Av. E.W.		82.5		78.4		71.5		17.0	
3/8" A514 E90	593A	82.6	69.6	74.2	69.1	74.8	78.0	23.7	22.6
	B	85.1	71.7	76.8	75.4	71.0	75.4	23.6	22.4
	C	82.6	73.3	73.6	73.3	71.9	80.4	23.6	22.9
Average		83.4	71.5	74.9	72.6	72.6	77.9	23.6	22.6
Av. E.W.		77.5		73.8		75.2		23.1	
1/2" A514 E90	594A	81.9	72.6	74.9	72.1	73.1	76.5	30.7	24.9
	B	83.2	72.4	77.8	73.5	70.2	77.4	30.4	25.4
	C	78.4	72.6	70.7	72.1	74.1	76.5	30.6	24.9
Average		81.2	72.5	74.5	72.6	72.5	76.8	30.6	25.1
Av. E.W.		76.9		73.6		74.6		27.9	
1/4" A514 E110	512A	94.7	82.5	85.2	82.5	76.8	72.9	21.3	15.7
	B	92.9	85.8	77.4	90.7	74.0	83.6	20.9	16.1
	C	99.4	80.1	92.7	79.2	79.5	81.1	20.9	16.2
Average		95.7	82.8	85.1	84.1	76.7	79.2	21.0	16.0
Av. E.W.		89.1		84.8		77.9		18.5	

\* NOTES

S<sub>T</sub> K/Sq. In. – ultimate stress based on measured throat dimension T

S<sub>P</sub> K/Sq. In. – ultimate stress based on measured penetration P

S<sub>W</sub> K/Sq. In. – ultimate stress based on measured fracture width W

S<sub>K</sub> K/Lin. In. – total failure load divided by total weld length

See Drawing D-3 for location of symbols T, P and W.

TABLE 5 (CONT.)  
SUMMARY OF CALCULATED STRESS

LONGITUDINAL FILLET WELDS

SIZE	SPEC. NO.	S <sub>T</sub> K/SQ. IN.*		S <sub>P</sub> K/SQ. IN.*		S <sub>W</sub> K/SQ. IN.*		S K/LIN. IN.*	
		East	West	East	West	East	West	East	West
3/8" A514 E110	513A	100.8	74.1	91.6	77.3	76.9	73.5	27.5	22.4
	B	100.3	81.2	86.2	79.9	77.2	82.5	27.6	25.0
	C	104.6	76.9	97.2	78.8	86.4	78.8	27.2	24.4
Average		101.9	77.4	91.6	78.7	80.2	78.3	27.4	23.9
Av. E.W.		89.6		85.2		79.3		25.6	
1/2" A514 E110	514A	90.8	79.5	84.6	79.5	80.2	80.0	34.5	28.8
	B	90.1	83.9	86.8	83.9	83.3	81.1	35.6	29.6
	C	90.0	84.5	87.2	86.3	80.1	84.5	34.4	30.0
Average		90.3	82.6	86.2	83.2	81.2	81.9	34.8	29.5
Av. E.W.		86.5		84.7		81.6		32.2	
Average									
Av. E.W.									
Average									
Av. E.W.									

**\* NOTES**

S<sub>T</sub> K/Sq. In. – ultimate stress based on measured throat dimension T

S<sub>P</sub> K/Sq. In. – ultimate stress based on measured penetration P

S<sub>W</sub> K/Sq. In. – ultimate stress based on measured fracture width W

S<sub>K</sub> K/Lin. In. – total failure load divided by total weld length

See Drawing D-3 for location of symbols T, P and W.

**TABLE 6  
SUMMARY OF CALCULATED STRESS**

**1/4" TRANSVERSE FILLET WELDS**

Base-Metal Electrode	SPEC. NO.	ST K/SQ. IN.*		SP K/SQ. IN.*		SW K/SQ. IN.*		S K/LIN. IN.*	
		East	West	East	West	East	West	East	West
A36 E70	T37A	121.7	113.5	118.8	100.4	101.7	96.0	24.9	21.6
	B	115.1	117.5	110.0	98.7	93.5	92.5	24.8	21.7
	C	115.3	119.0	110.0	99.6	88.5	95.2	24.8	21.4
Average		114.0	116.7	112.6	99.6	94.6	94.6	24.2	21.6
Av. E.W.		115.3		101.1		94.6		22.9	
A441 E70	T47A	124.2	125.0	118.5	113.3	85.5	101.2	26.1	23.8
	B	124.0	136.8	115.9	126.5	92.0	103.2	26.6	25.2
	C	130.5	134.5	110.6	110.0	97.8	101.0	25.4	24.2
Average		126.2	132.1	115.0	116.6	91.8	101.8	26.0	24.4
Av. E.W.		129.0		115.8		96.8		25.2	
A514 E70	T57A	126.4	116.0	123.4	98.4	96.8	94.5	24.7	22.6
	B	130.8	119.0	121.3	118.0	98.2	92.8	25.5	23.2
	C	129.0	104.1	123.0	92.3	98.3	78.0	27.2	20.3
Average		128.7	113.0	122.6	102.9	97.8	88.4	25.8	22.0
Av. E.W.		120.8		112.7		92.1		23.9	
A441 E90	T49A	133.0	107.3	124.0	102.2	95.5	99.7	27.2	21.0
	B	124.0	110.4	116.4	99.8	94.5	90.8	27.9	20.4
	C	123.6	110.0	115.0	93.8	87.5	87.5	25.7	19.2
Average		126.9	109.1	118.5	98.6	92.5	92.7	26.9	20.3
Av. E.W.		117.9		102.6		92.6		23.4	

**\* NOTES**

ST K/Sq. In. -- ultimate stress based on measured throat dimension T

SP K/Sq. In. -- ultimate stress based on measured penetration P

SW K/Sq. In. -- ultimate stress based on measured fracture width W

SK K/Lin. In. -- total failure load divided by total weld length

See Drawing D-6 for location of symbols T, P and W.

TABLE 6 (CONT.)  
SUMMARY OF CALCULATED STRESS

¼" TRANSVERSE FILLET WELDS

Base-Metal Electrode	SPEC. NO.	S <sub>T</sub> K/SQ. IN.*		S <sub>P</sub> K/SQ. IN.*		S <sub>W</sub> K/SQ. IN.*		S K/LIN. IN.*	
		East	West	East	West	East	West	East	West
A514 E90	T59A	126.0	123.8	123.4	115.0	109.5	109.8	29.0	24.2
	B	136.0	127.5	119.5	115.7	101.0	95.5	29.2	24.8
	C	125.8	125.0	111.2	122.0	91.8	119.0	28.9	25.6
Average		129.2	125.4	118.0	117.6	100.7	108.1	29.0	24.9
Av. E.W.		127.3		117.8		104.4		26.9	
A514 E110	T51A	155.5	156.0	155.5	136.9	124.5	119.5	34.2	28.0
	B	159.0	147.5	152.3	136.0	117.3	109.0	35.8	27.2
	C	157.0	133.0	153.7	127.0	112.6	116.0	33.8	27.3
Average		157.2	145.5	153.8	133.3	114.8	114.8	34.6	27.5
Av. E.W.		151.3		143.0		114.8		32.1	
Average									
Av. E.W.									
Average									
Av. E.W.									

**\* NOTES**

S<sub>T</sub> K/Sq. In. — ultimate stress based on measured throat dimension T

S<sub>P</sub> K/Sq. In. — ultimate stress based on measured penetration P

S<sub>W</sub> K/Sq. In. — ultimate stress based on measured fracture width W

S<sub>K</sub> K/Lin. In. — total failure load divided by total weld length

See Drawing D-6 for location of symbols T, P and W.

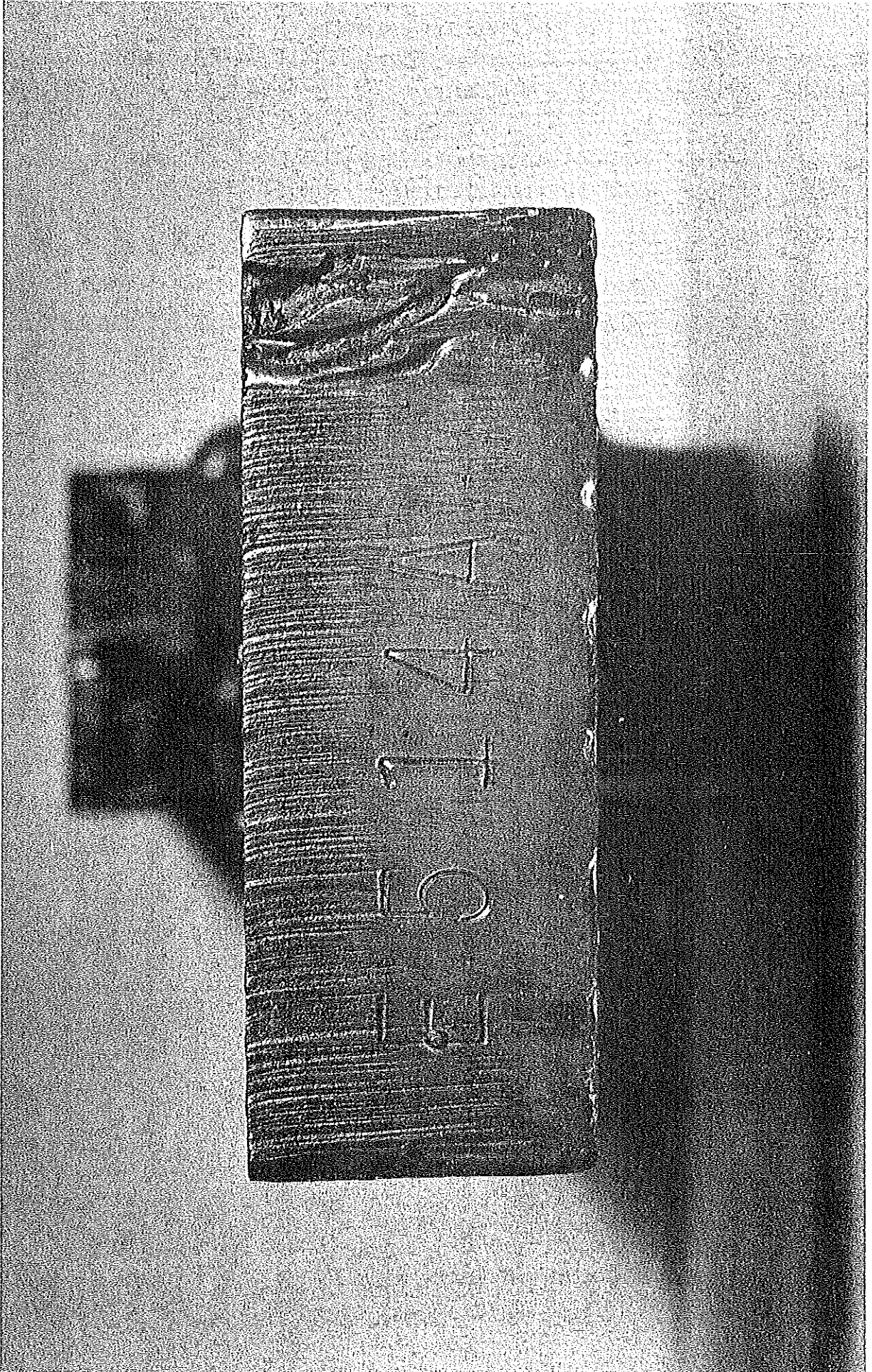

Photo No. 2

Technical Longitudinal Bullet Mold Sample Showing Identification Mark Stamp On End



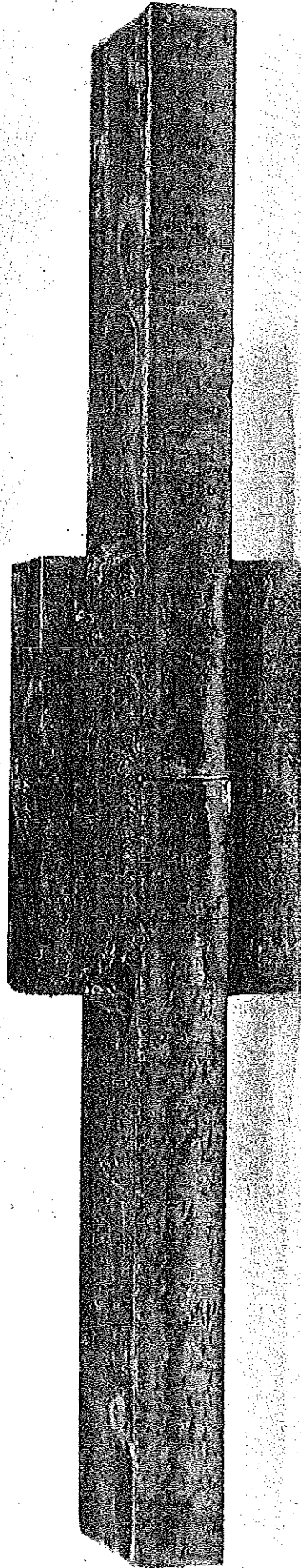

Photo No. 1

Typical Longitudinal Fillet Weld Specimen As Welded

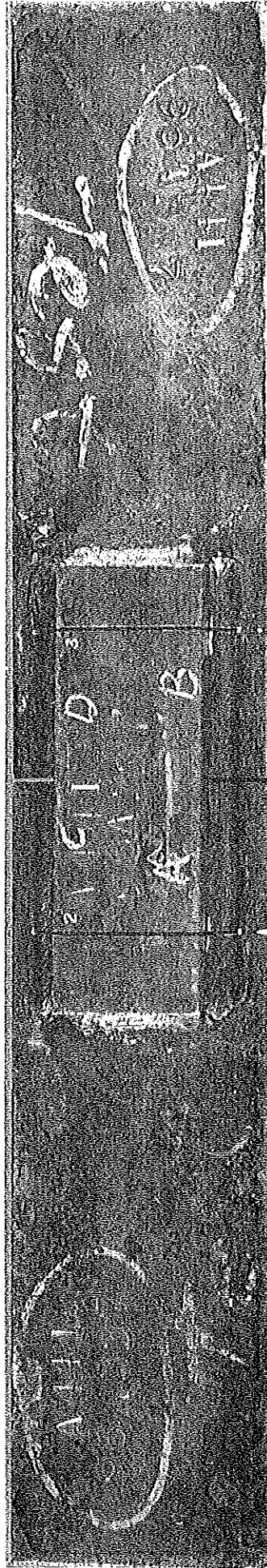

Photo No. 3

Typical Longitudinal fillet weld specimen as machined. Six cuts were made with a bandsaw.

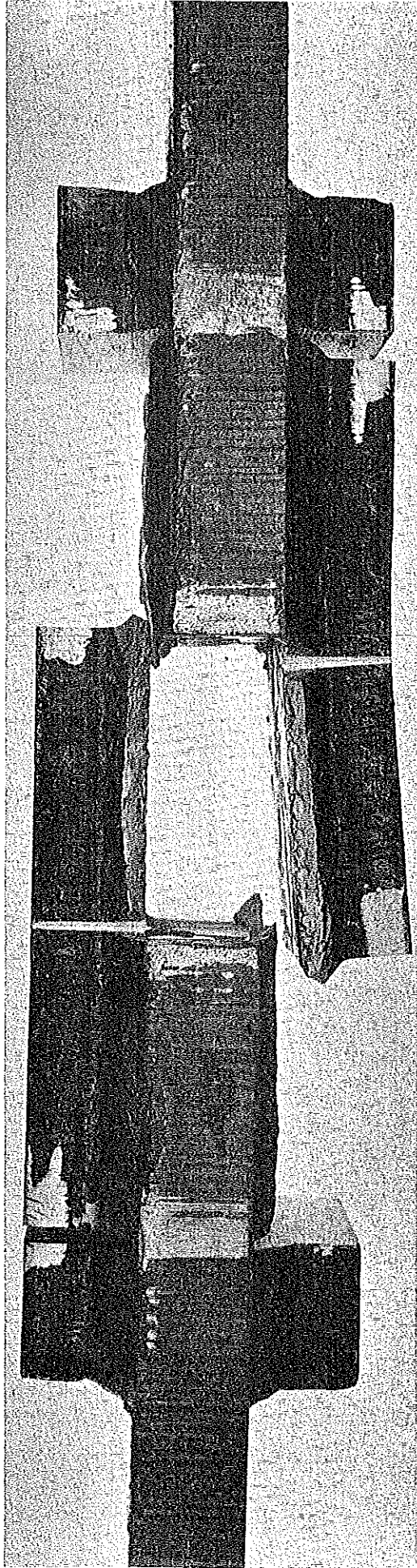

Photo No. 4

Longitudinal fillet weld specimen after testing. This is typical of one of two types of weld fractures.

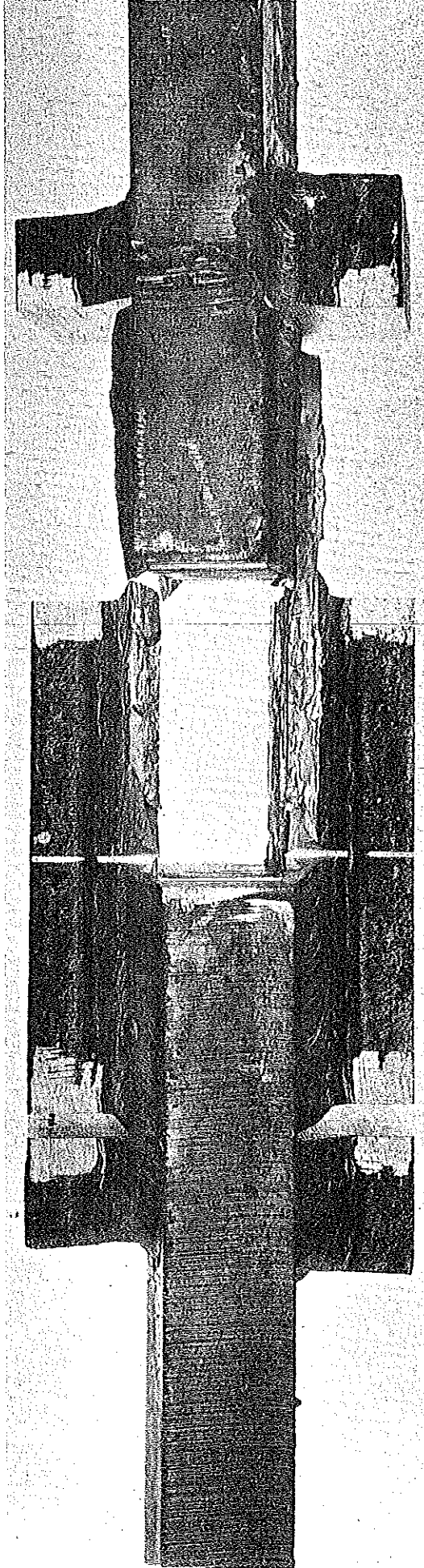

Photo No. 5

Longitudinal fillet weld specimen after testing. This is typical of second of two types of weld fracture that occurred.





Photo No. 6

Closeup view of longitudinal fillet weld after fracture. The fracture face (arrow) is typical. The width (W) of fracture is average of several measurements across this face.

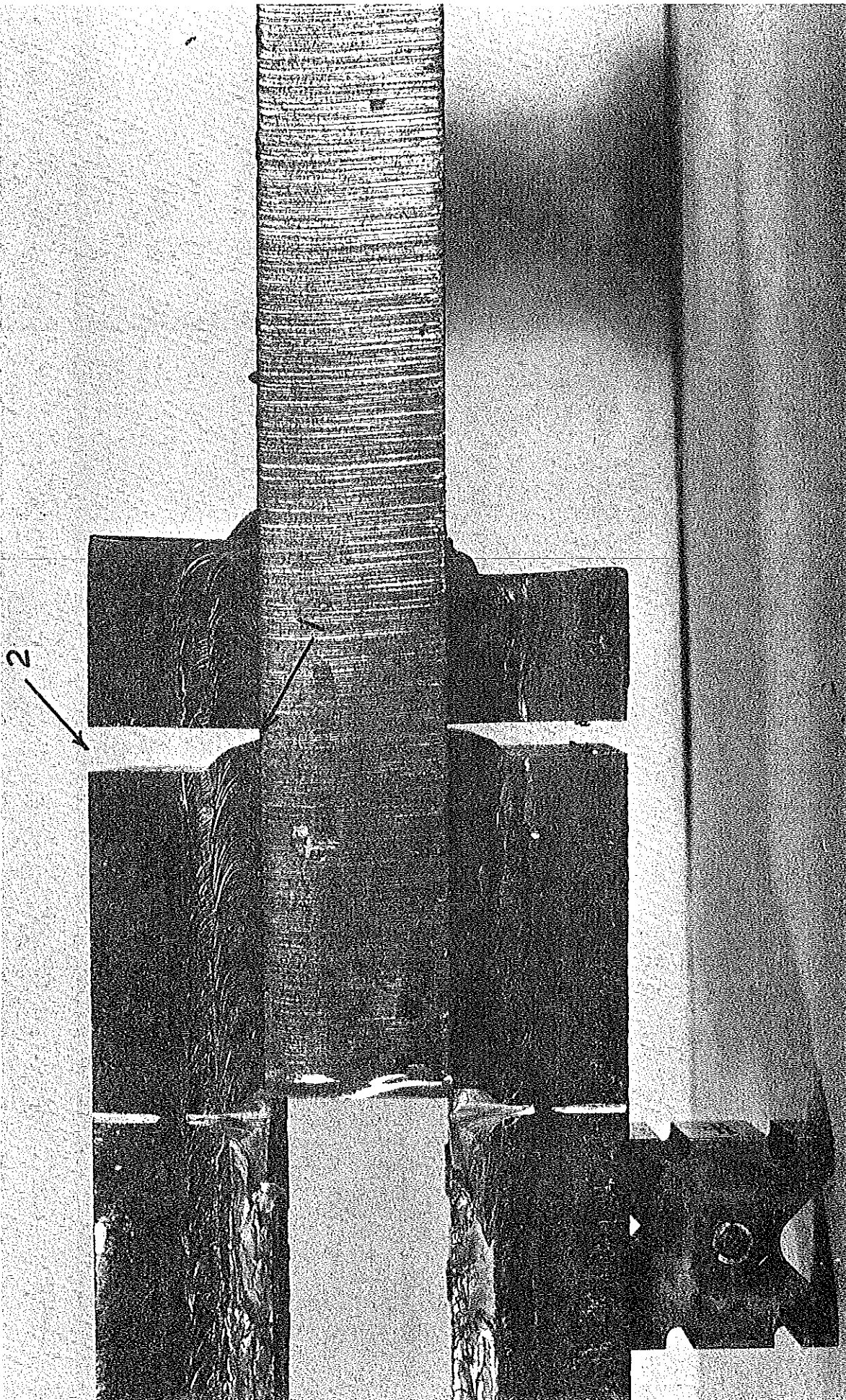

Photo No. 7

Side view of typical longitudinal fillet weld specimen after fracture. Elongation in unfailed weld is shown by difference in notch dimensions. Arrow 1 is original. Arrow 2 is final.



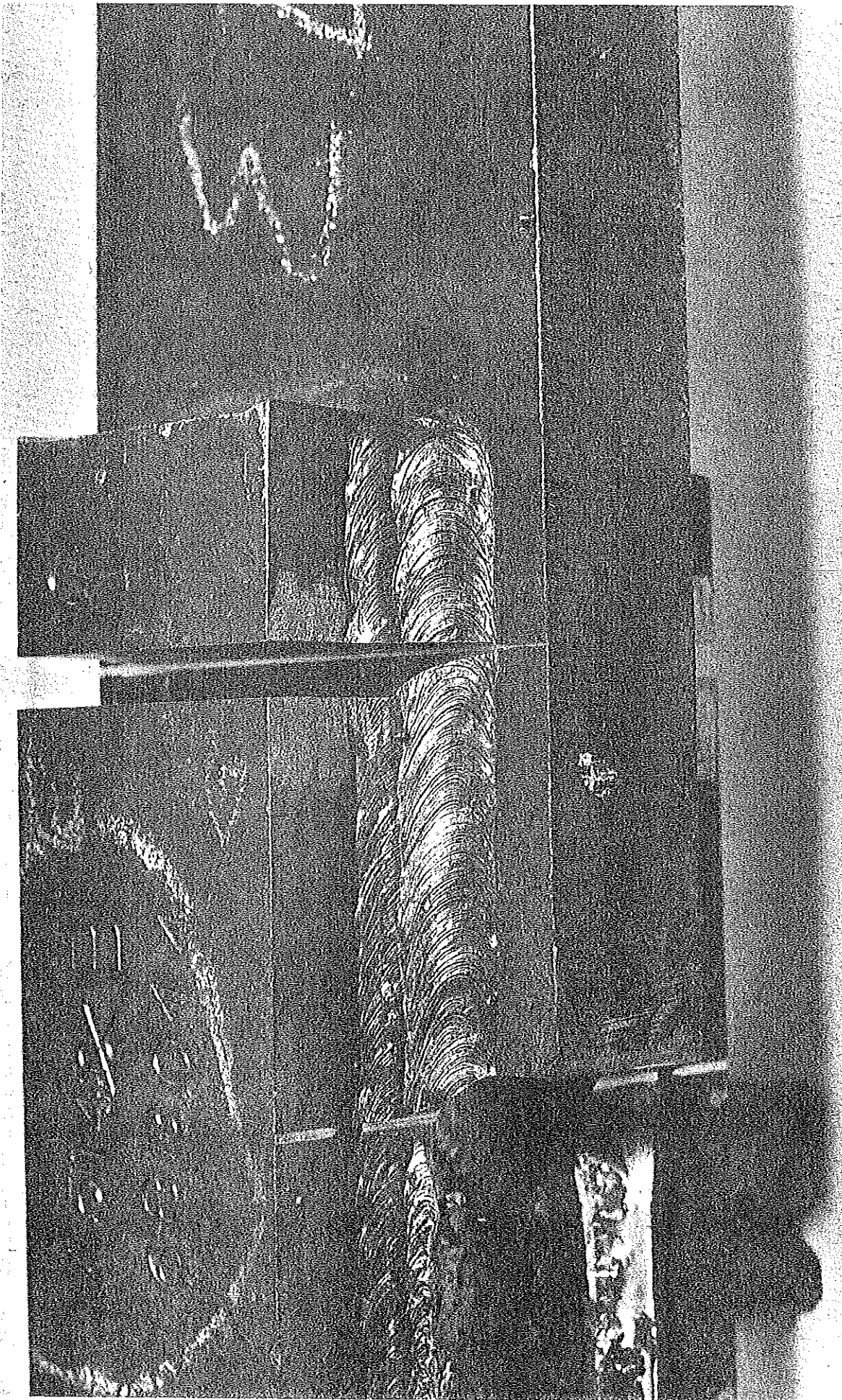

Photo No. 8

Closer view of upper weld in Photo No. 7. Ductility and elongation of weld metal are readily apparent.

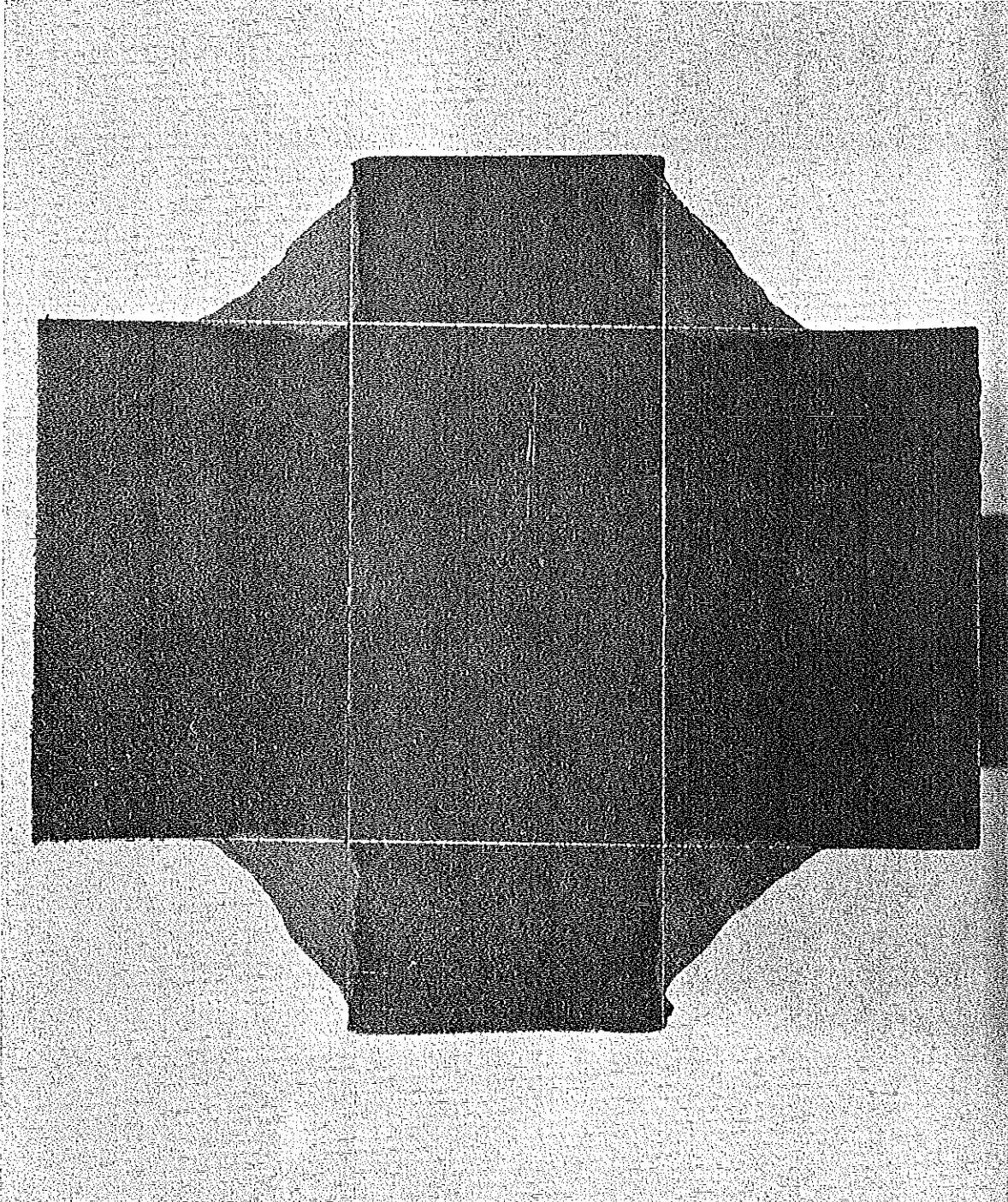

Photo No. 9

Typical macro-etched cross section of unfailed longitudinal fillet weld specimen prepared for measurement of legs, throats and penetration.



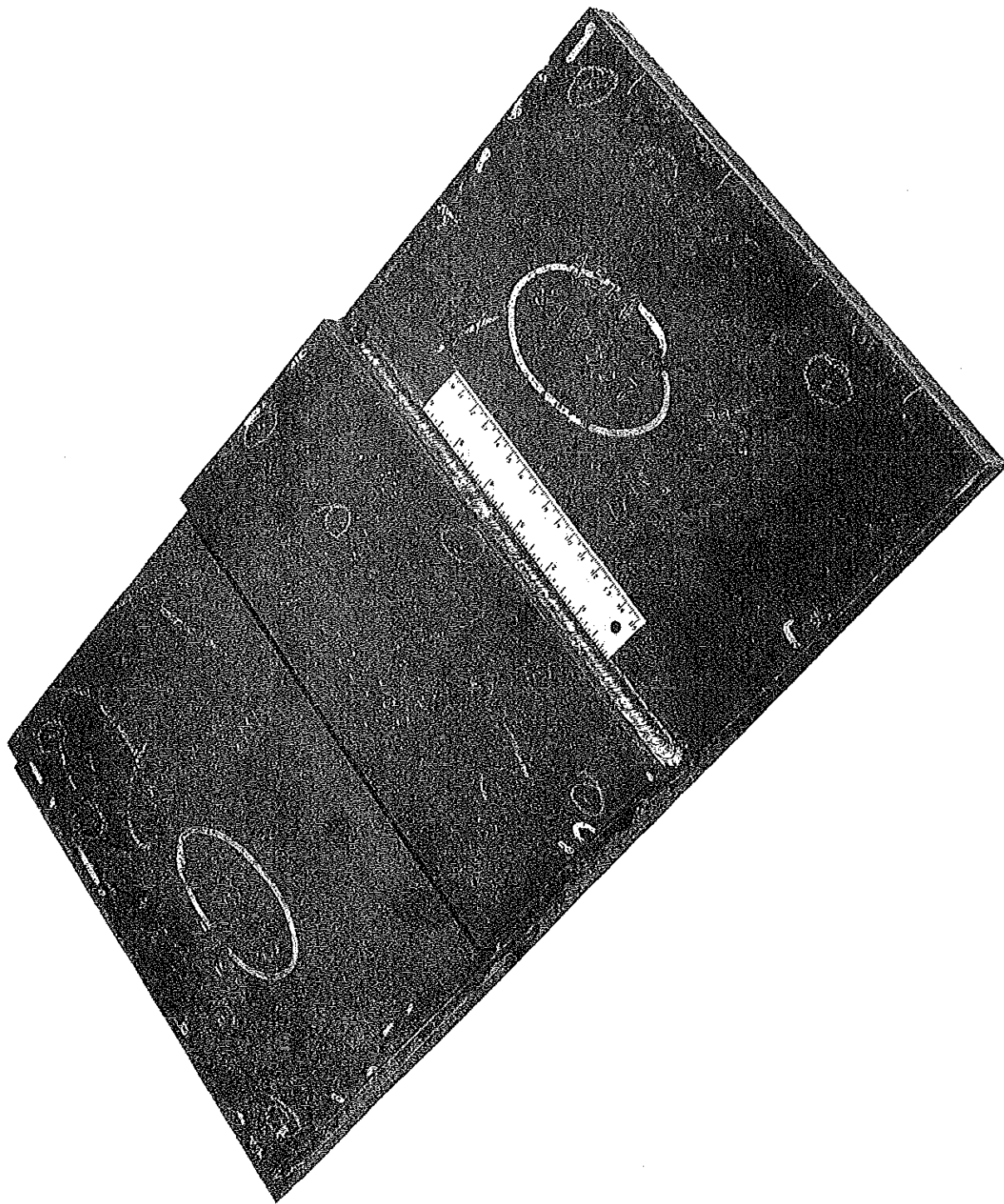

Photo No. 10

Typical transverse fillet weld plate as received. Three test specimens were machined from each plate.

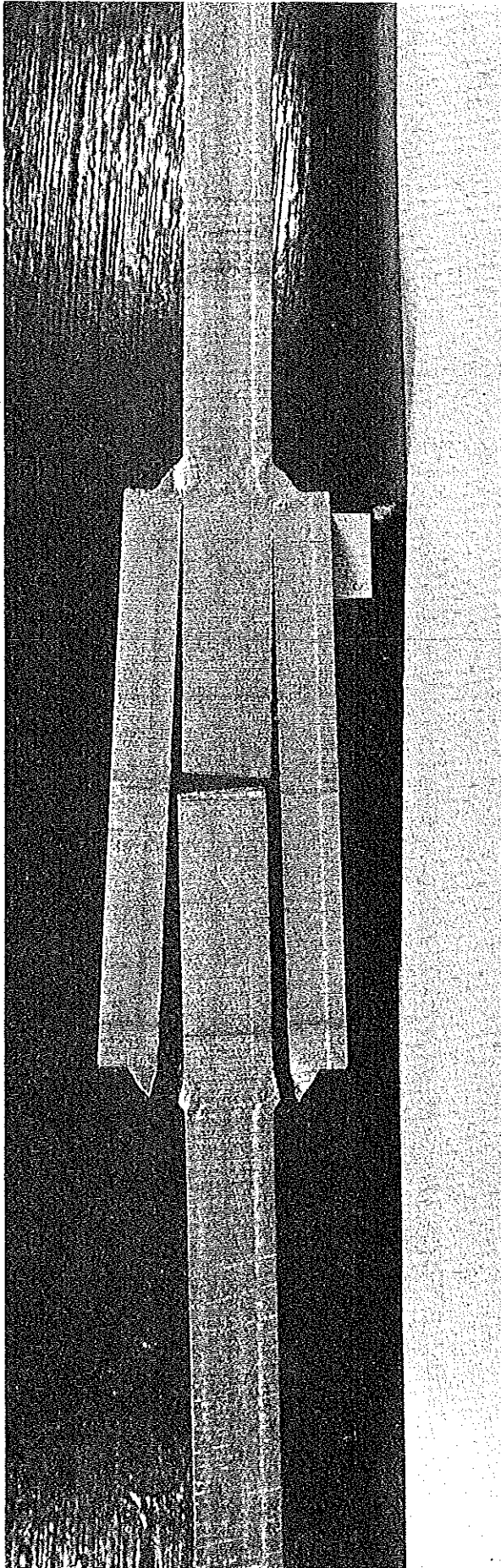

Photo No. 11

Transverse fillet weld specimen after testing. This is typical of one of two types of weld fracture. Note flat angle that weld fracture makes with horizontal.

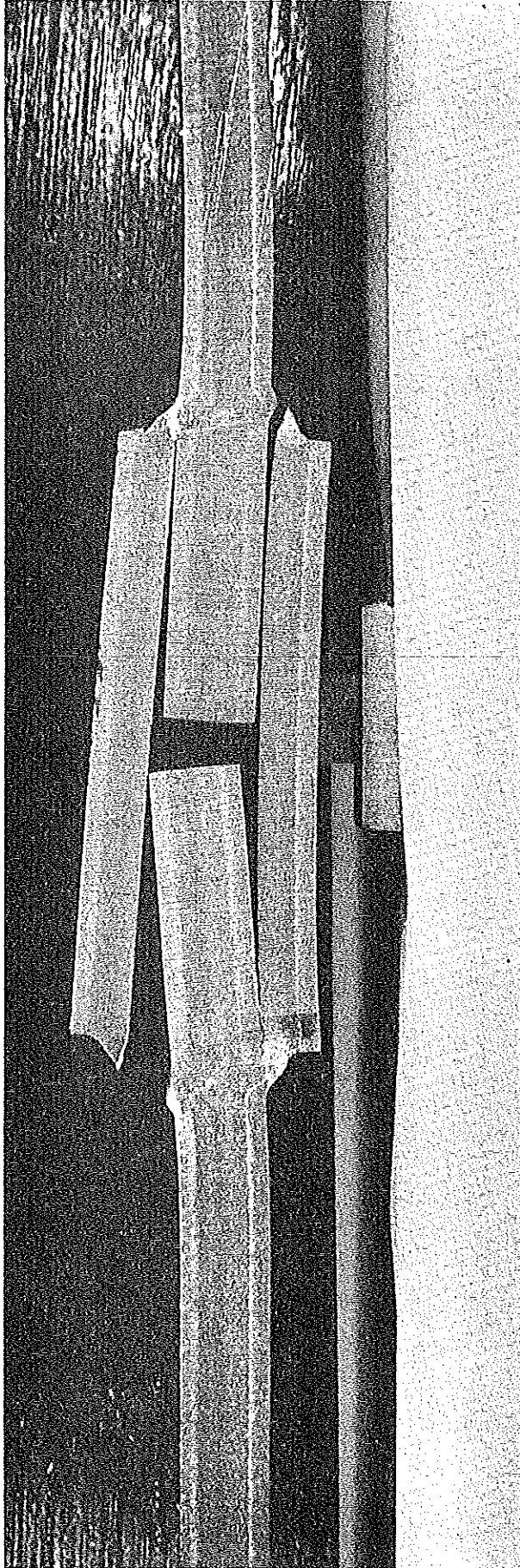

Photo No. 12

Transverse fillet weld specimen after testing. This is typical of second of two types of weld fracture.

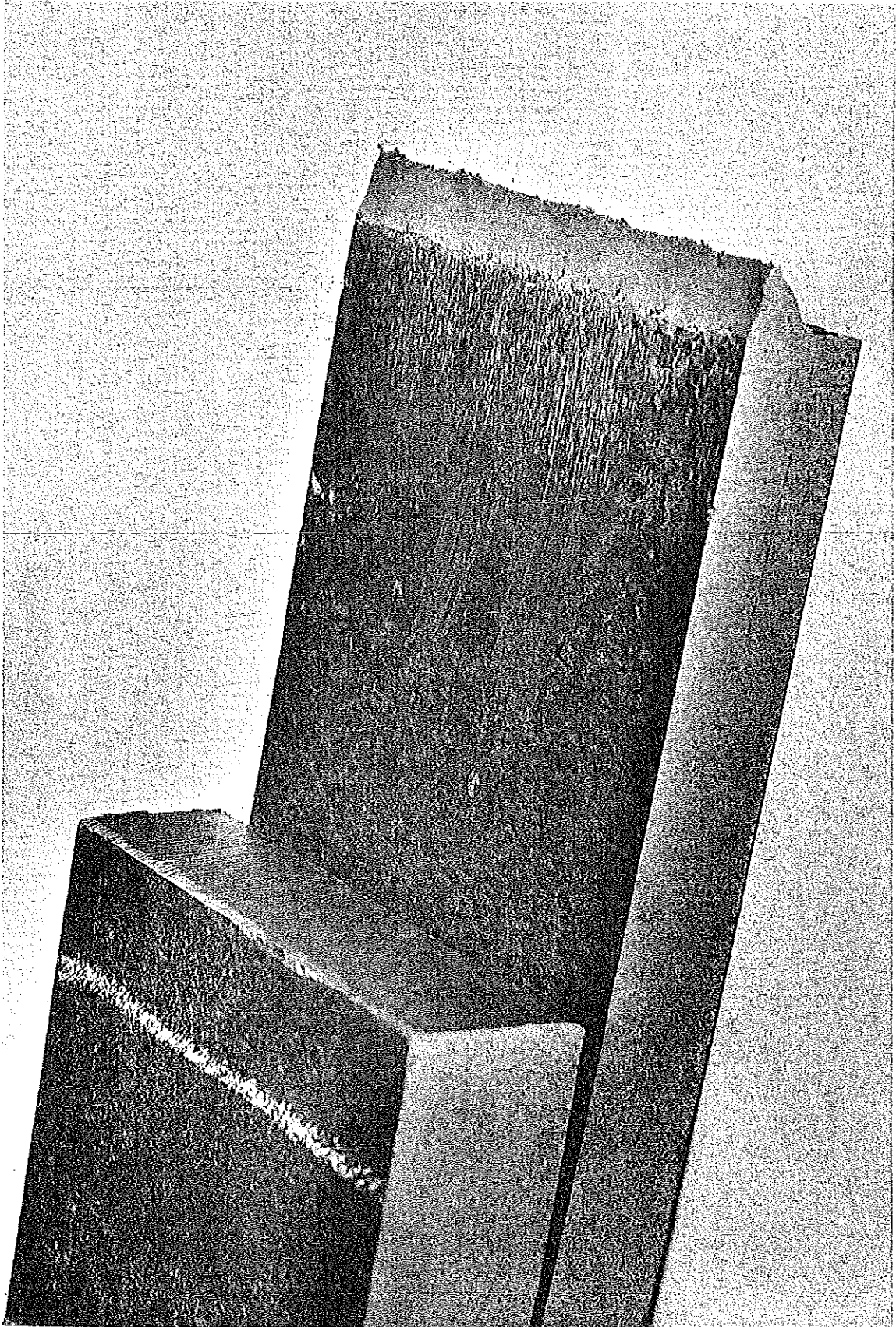

Photo No. 13

Closeup view of typical transverse fillet weld fracture. Fracture face is almost in same plane as base metal.



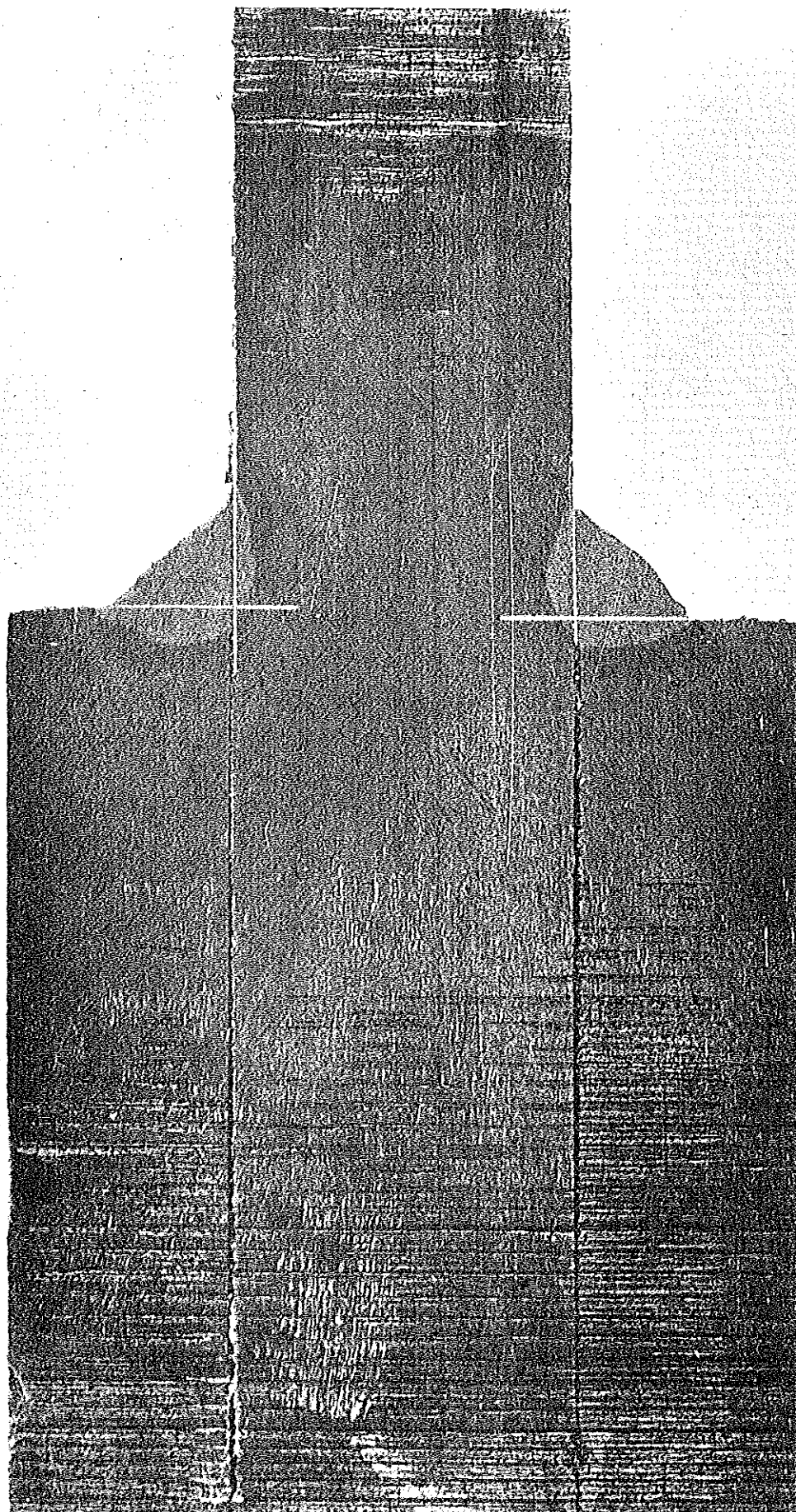
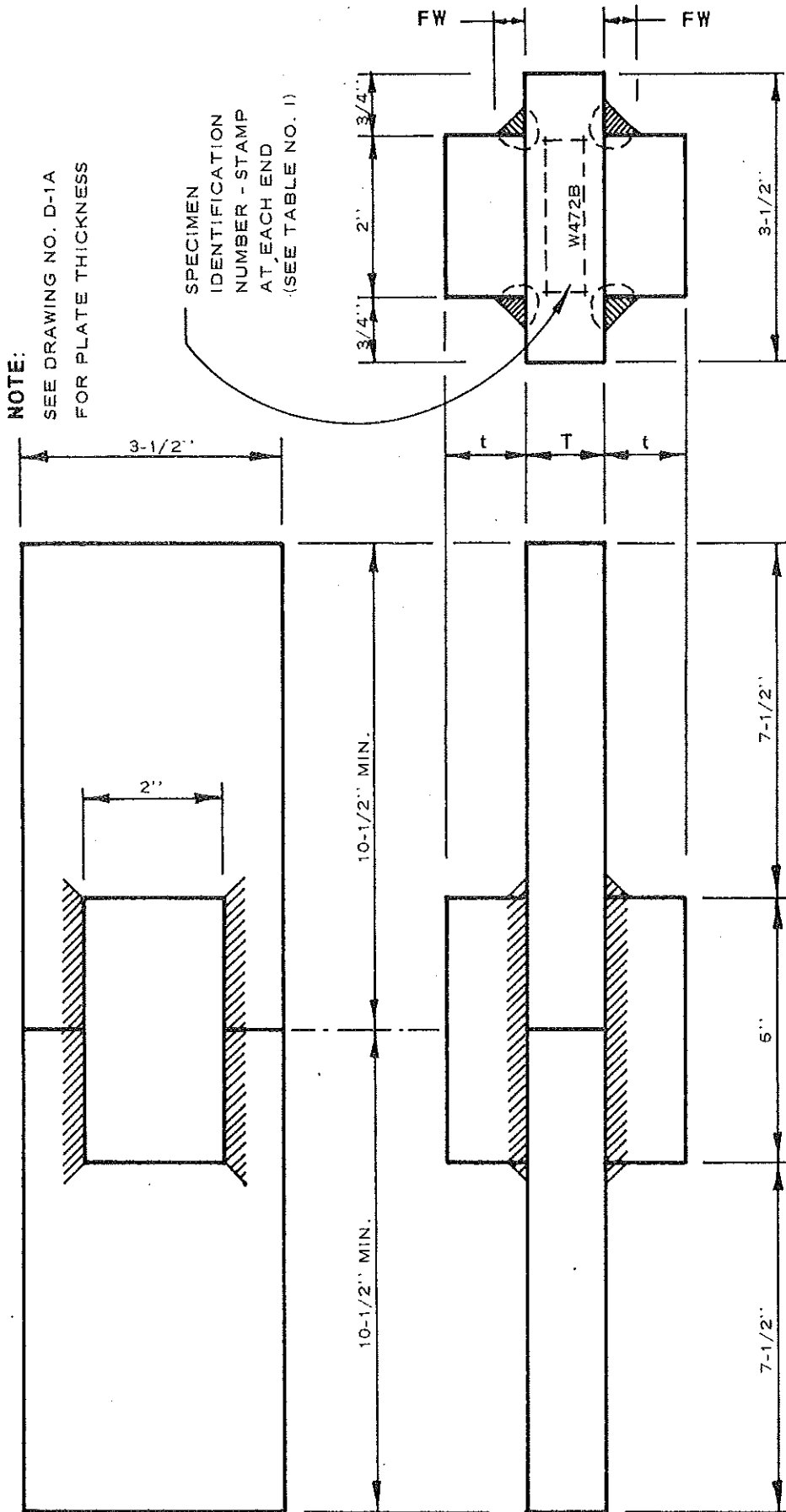

Photo No. 14

Typical macro-etched cross section of unfailed transverse fillet welds prepared for measurement of legs, throat and penetration distance.

# PROPOSED LONGITUDINAL FILLET WELD TEST

AWS TEST SPECIMEN MODIFIED TO COVER VARIATIONS IN MATERIALS AND ELECTRODE AND TO INSURE FAILURE OF WELDS RATHER THAN BASE METAL



SPECIMEN BLANK  
AFTER WELDING - BEFORE MACHINING  
DRAWING D-1

**PROPOSED LONGITUDINAL FILLET WELD TEST**

**AWS TEST SPECIMEN MODIFIED TO COVER  
VARIATIONS IN MATERIALS AND ELECTRODE**

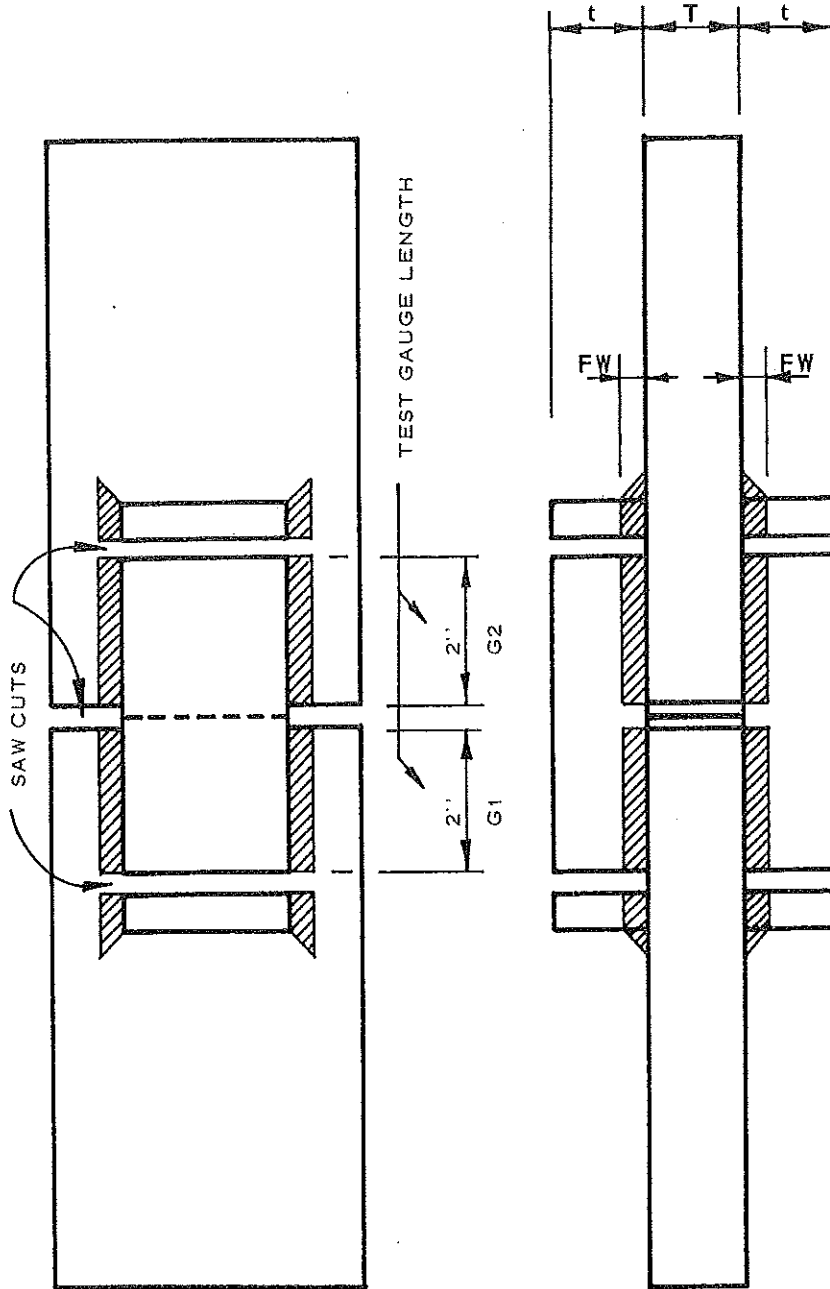

**DIMENSION SCHEDULE**

WELD SIZE - "FW"	1/4"	3/8"	1/2"
MAIN PLATE THICKNESS - "T"	3/4"	1"	1-1/4"
SPLICE PLATES THICKNESS - "t"	3/4"	1"	1-1/4"

**SPECIMEN BLANK  
AFTER MACHINING  
DRAWING D - 2**

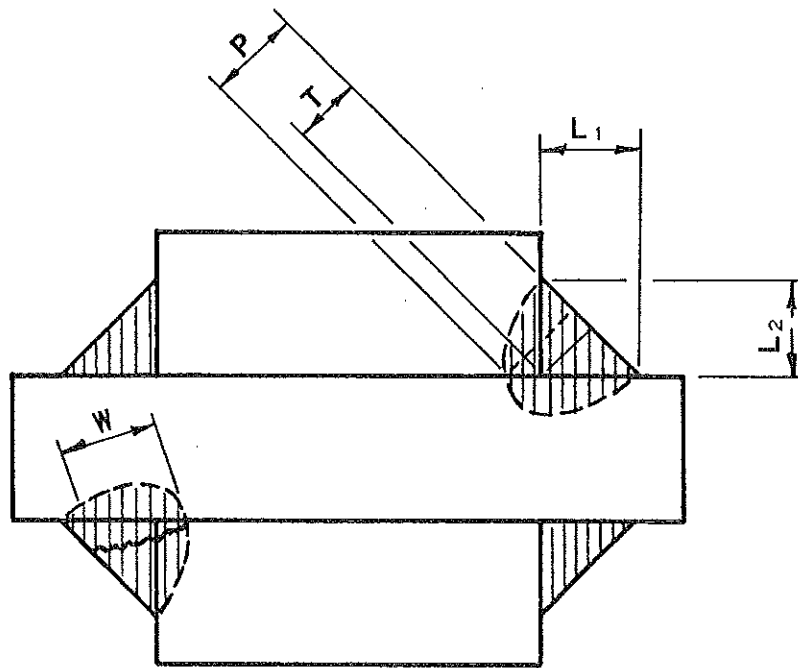

### CROSS SECTION

**NOTE:** CROSS SECTION OF UNFAILED PORTION OF SPECIMEN TO BE CUT AND ETCHED. VERTICAL AND HORIZONTAL LINES ARE TO BE SCRIBED CORRESPONDING TO THE ORIGINAL PLATE SURFACES AND THE VERTICAL AND HORIZONTAL LEG SIZES. "L" ARE TO BE MEASURED AND THE MAXIMUM AND MINIMUM VALUES RECORDED ON THE DATA SHEET. THE "ACTUAL" THROAT, T, IS ALSO TO BE MEASURED AND RECORDED. T IS DEFINED AS THE DISTANCE TO THE FACE OF THE WELD FROM THE INTERSECTION OF THE ORIGINAL PLATE SURFACES. W IS DEFINED AS THE AVERAGE WIDTH OF THE FRACTURED SURFACE. MEASUREMENTS SHALL BE TAKEN WITH A MACHINISTS SCALE TO THE NEAREST HUNDREDTH OF AN INCH.



**PROPOSED TRANSVERSE FILLET WELD TEST**

**AWS TEST SPECIMEN MODIFIED TO COVER  
VARIATIONS IN MATERIALS AND ELECTRODES**

ALL WELDS TO BE 1/4" FILLET WELDS

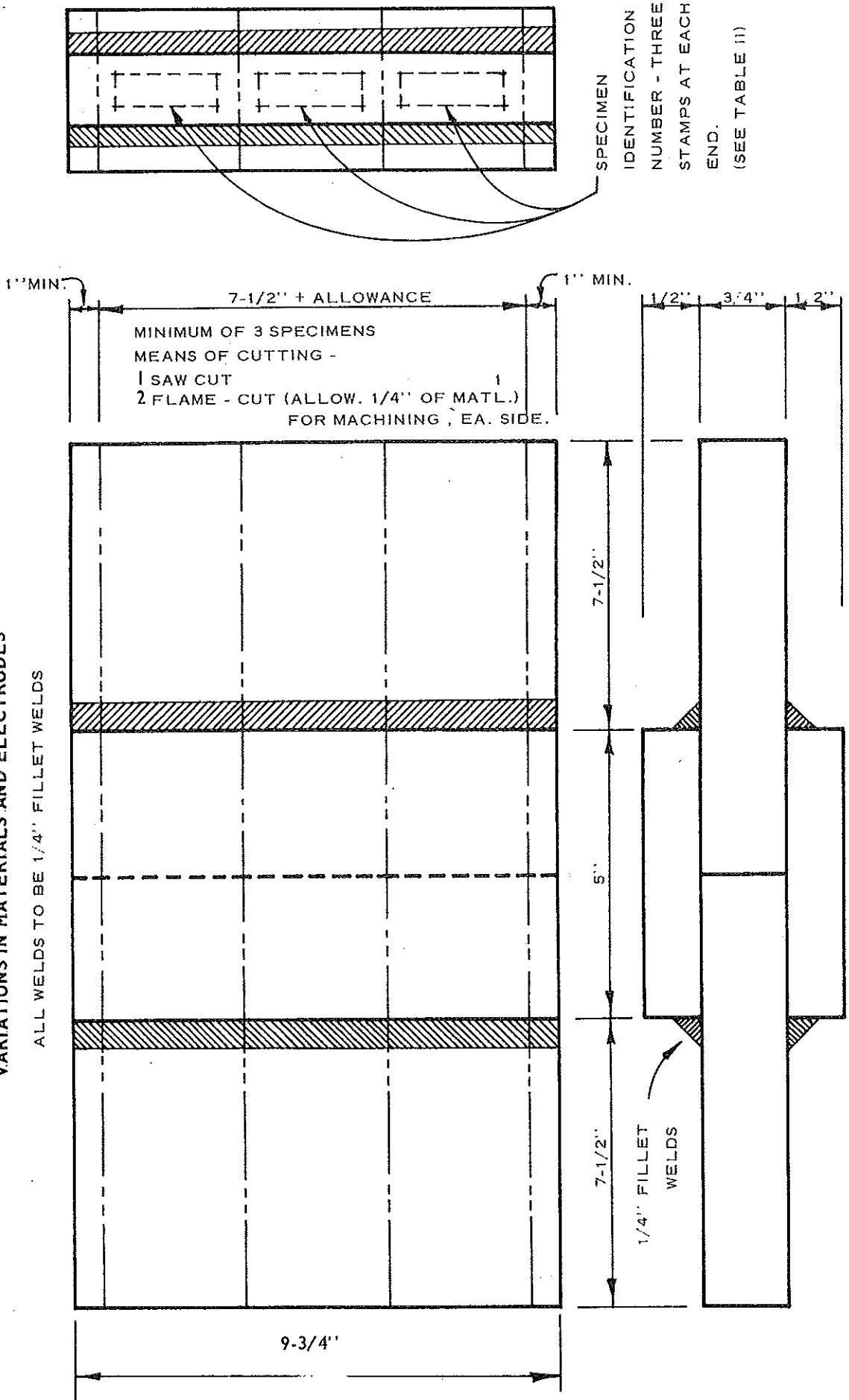

**SPECIMEN BLANK - BEFORE MACHINING**

**DRAWING D - 4**

# PROPOSED TRANSVERSE FILLET WELD TEST

AWS TEST SPECIMEN MODIFIED TO COVER  
VARIATIONS IN MATERIALS AND ELECTRODES

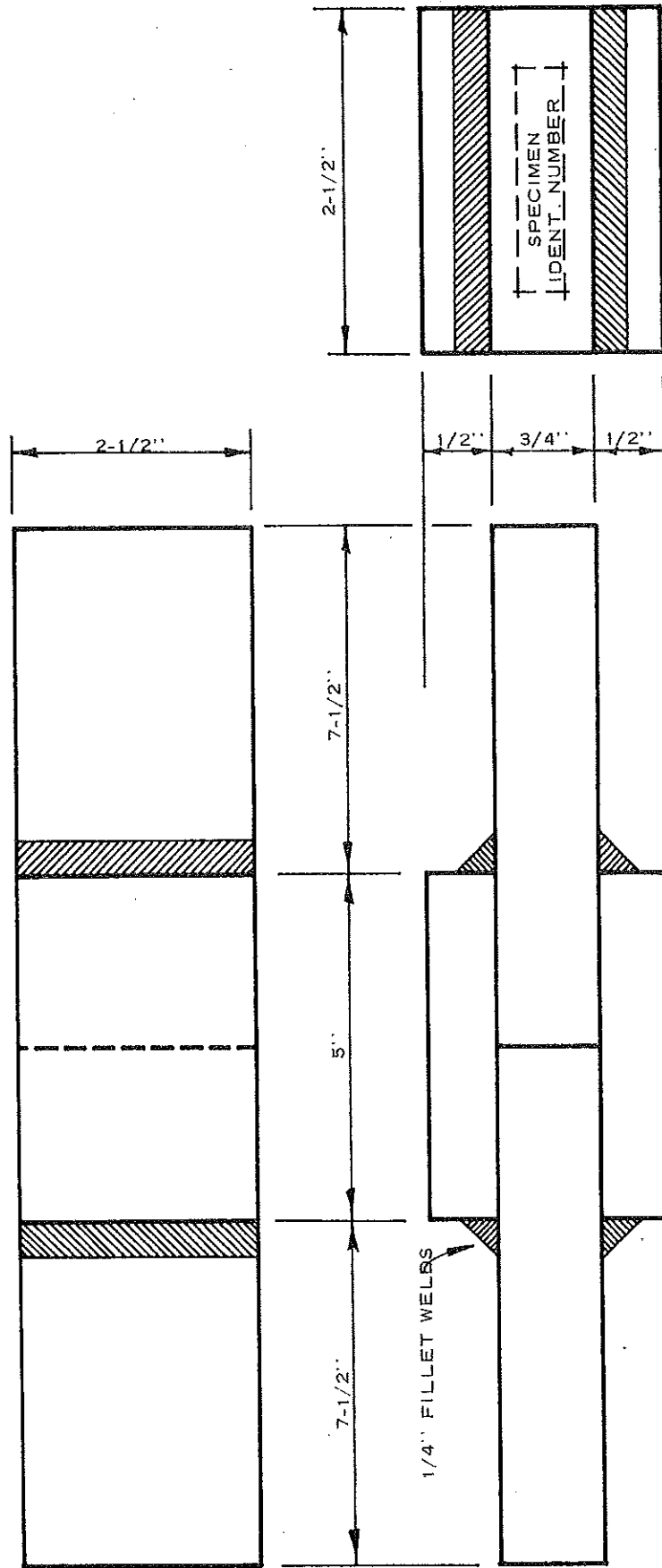

SPECIMEN BLANK - AFTER MACHINING  
DRAWING D - 5

DRAWING NO. D-6

TRANSVERSE WELD TEST SPECIMEN

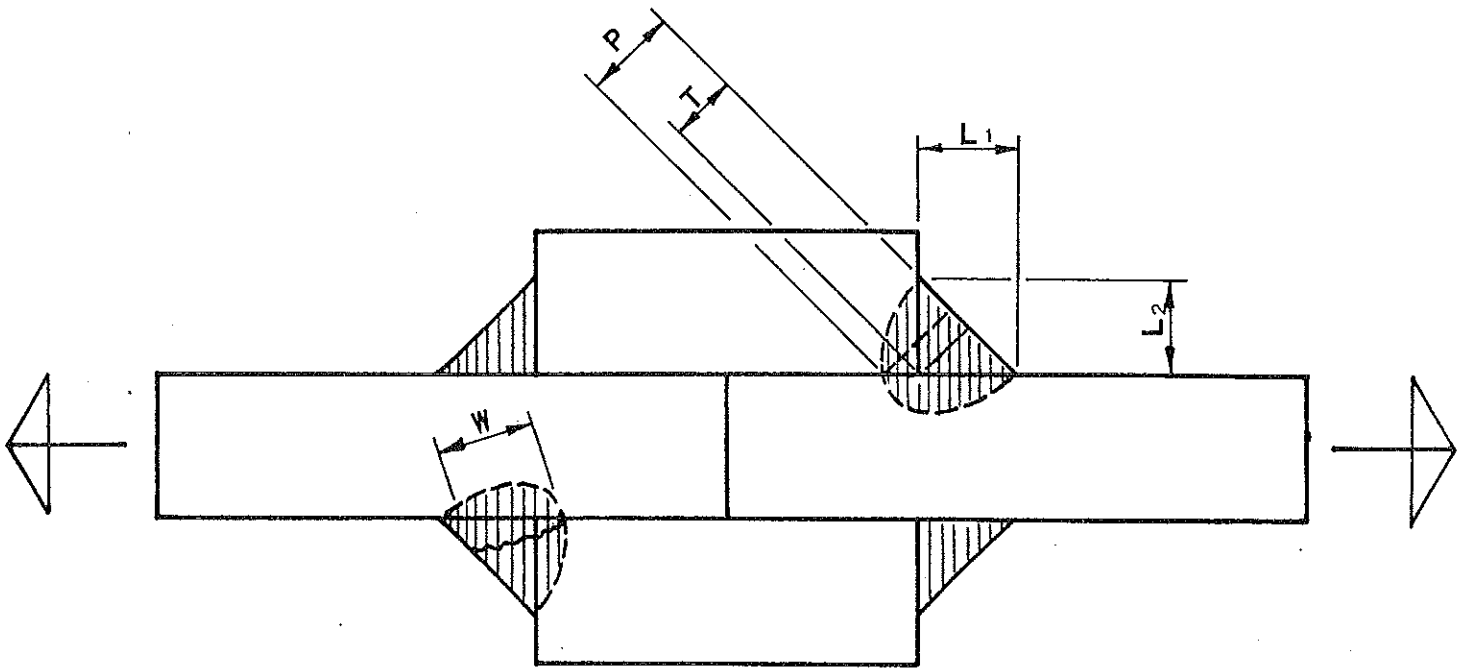

CROSS SECTION

**NOTE:** CROSS SECTION TO BE ETCHED IS MACHINED SIDE ELEVATION OF SPECIMEN. VERTICAL AND HORIZONTAL LINES ARE TO BE SCRIBED CORRESPONDING TO THE ORIGINAL PLATE SURFACES AND THE VERTICAL AND HORIZONTAL LEG SIZES, "L" ARE TO BE MEASURED AND THE MAXIMUM AND MINIMUM VALUES RECORDED ON THE DATA SHEET. THE "ACTUAL" THROAT, "T" IS ALSO TO BE MEASURED AND RECORDED. "T" IS DEFINED AS THE DISTANCE TO THE FACE OF THE WELD FROM THE INTERSECTION OF THE ORIGINAL PLATE SURFACES. "W" IS DEFINED AS THE AVERAGE WIDTH OF THE FRACTURED SURFACE. MEASUREMENTS SHALL BE TAKEN WITH A MACHINISTS SCALE TO THE NEAREST HUNDREDTH OF AN INCH.

**TABLE I - SCHEDULE OF MATERIAL AND ELECTRODE COMBINATIONS AND IDENTIFICATION NUMBERS**

FABRICATOR	ELECTRODE	E-6012			E-7018			E-9018			E-11018					
		BASE METAL	WELD SIZE	1/4"	3/8"	1/4"	3/8"	1/2"	1/4"	3/8"	1/2"	1/4"	3/8"	1/2"		
WEST COAST (W)	A-36	W362A	W363A	W372A	W373A	W374A	W392A	W493A	W494A	W412A	<b>NOTE: NO TEST REQUIRED</b>					
		W362B	W363B	W372B	W373B	W374B	W392B	W493B	W494B	W412B						
		W362C	W363C	W372C	W373C	W374C	W392C	W493C	W494C	W412C						
	A-441			W472A	W473A	W474A	W492A	W593A	W594A	W512A				W513A	W514A	
				W472B	W473B	W474B	W492B	W593B	W594B	W512B				W513B	W514B	
				W472C	W473C	W474C	W492C	W593C	W594C	W512C				W513C	W514C	
	A-514			W572A	W573A	W574A	W592A	W593A	W594A	W512A				W513A	W514A	
				W572B	W573B	W574B	W592B	W593B	W594B	W512B				W513B	W514B	
				W572C	W573C	W574C	W592C	W593C	W594C	W512C				W513C	W514C	
	EAST COAST (E)	A-36														
A-441																
A-514																

**NOTE - ONLY 1 SPECIMEN REQUIRED OF EACH IDENTIFICATION NUMBER**

**IDENTIFICATION NUMBER KEY**

- 1ST DIGIT - FABRICATOR IDENTIFICATION - "W" OR "E"
- 2ND DIGIT - BASE METAL IDENTIFICATION - 3 = A-36, 4 = A-441, 5 = A-514
- 3RD DIGIT - ELECTRODE TYPE - 7 = E70, 9 = E90, 1 = E110
- 4TH DIGIT - WELD SIZE - 2 = 1/4", 3 = 3/8", 4 = 1/2"
- 5TH DIGIT - SEQUENCE OF SAMPLE PREPARATION FOR EACH TYPE SPECIMEN - A, B, & C

## DATA SHEET - LONGITUDINAL FILLET WELDS

EGO  
 $W = \frac{1}{4}"$  A36 West

SPECIMEN NO.	GAUGE LENGTH	L1	L2	P	T	W	LOAD KIPS
W362A $\frac{1}{4}"$	1.96	.34	.40	.23	.26	.23	84.5
$\frac{1}{4}"$ A36 West	1.98	.28	.25	.20	.20	.22	
	2.03	.28	.30	.21	.21	.20	
	2.01	.28	.28	.21	.21	.20	
Average or Total	7.98	.30	.31	.21	.22	.21	50.4 ksi
W362B	1.97	.39	.32	.22	.25	.22	84.0
$\frac{1}{4}"$ A36 West	1.97	.30	.32	.20	.20	.22	
	1.98	.32	.30	.19	.22	.21	
	2.00	.30	.27	.20	.20	.20	
Average or Total	7.92	.33	.30	.20	.22	.21	50.5 ksi
W362C	1.96	.31	.31	.19	.22	.16	81.0
$\frac{1}{4}"$ A36 West	1.91	.32	.27	.21	.21	.21	
	1.94	.35	.33	.23	.25	.22	
	1.96	.29	.28	.20	.20	.21	
Average or Total	7.77	.32	.30	.21	.22	.20	52.1 ksi

NOTES: DIMENSIONS GIVEN ARE IN INCHES  
 SEE DRAWING D-3 FOR LOCATION OF SYMBOLS L, P, T & W

## DATA SHEET - LONGITUDINAL FILLET WELDS

E60  
W = 3/8

SPECIMEN NO.	GAUGE LENGTH	L 1	L 2	P	T	W	LOAD KIPS
W363A	1.97	.40	.44	.32	.30	.29	122.0
	1.97	.44	.45	.32	.32	.28	
	1.94	.50	.45	.32	.35	.28	
	1.96	.44	.49	.33	.33	.30	
Average or Total	7.84	.45	.46	.32	.33	.29	
W363B	1.94	.50	.50	.33	.33	.29	124.0
	2.00	.52	.54	.35	.35	.30	
	1.98	.49	.51	.32	.32	.28	
	1.99	.43	.49	.30	.30	.29	
Average or Total	7.91	.49	.51	.33	.33	.29	
W363C	2.01	.48	.43	.29	.32	.28	129.0
	2.00	.43	.43	.30	.30	.30	
	2.02	.43	.44	.30	.31	.31	
	2.02	.45	.46	.30	.33	.32	
Average or Total	8.05	.45	.44	.30	.32	.30	

NOTES: DIMENSIONS GIVEN ARE IN INCHES  
SEE DRAWING D-3 FOR LOCATION OF SYMBOLS L, P, T & W

## DATA SHEET - LONGITUDINAL FILLET WELDS

w = 1/2"

SPECIMEN NO.	GAUGE LENGTH	L 1	L 2	P	T	W	LOAD KIPS
W372A	1.99	.31	.34	.22	.22	.23	118.0
	2.00	.30	.34	.24	.23	.21	
	2.04	.31	.32	.22	.23	.22	
	2.01	.30	.34	.22	.22	.23	
Average or Total	8.04	.31	.34	.23	.23	.22	
W372B	1.97	.34	.33	.22	.22	.23	114.0
	1.97	.32	.29	.21	.21	.22	
	1.94	.31	.33	.23	.23	.23	
	1.96	.30	.35	.23	.23	.24	
Average or Total	7.84	.32	.33	.22	.22	.23	
W372C	1.92	.29	.33	.23	.23	.23	116.5
	1.97	.30	.30	.22	.22	.23	
	2.00	.30	.31	.22	.22	.24	
	1.99	.32	.33	.22	.22	.22	
Average or Total	7.88	.30	.32	.22	.22	.23	

NOTES: DIMENSIONS GIVEN ARE IN INCHES

SEE DRAWING D-3 FOR LOCATION OF SYMBOLS L, P, T &amp; W

A36

E70

49

## DATA SHEET - LONGITUDINAL FILLET WELDS

 $w = 3/8''$ 

SPECIMEN NO.	GAUGE LENGTH	L1	L2	P	T	W	LOAD KIPS
W373A	2.00	.43	.44	.29	.31	.28	147.0
	1.97	.42	.42	.30	.30	.27	
	2.03	.46	.44	.30	.33	.28	
	2.01	.45	.49	.33	.33	.34	
Average or Total	8.01	.44	.45	.31	.32	.29	
W373B	1.98	.50	.47	.29	.31	.29	150.0
	2.00	.57	.43	.30	.30	.29	
	1.99	.51	.44	.27	.30	.28	
	1.99	.47	.46	.27	.29	.29	
Average or Total	7.96	.51	.45	.28	.30	.29	
W373C	2.00	.45	.47	.32	.32	.29	151.0
	2.01	.45	.43	.29	.29	.28	
	1.97	.44	.45	.31	.31	.28	
	2.01	.43	.45	.31	.31	.28	
Average or Total	7.99	.44	.45	.31	.31	.28	

NOTES: DIMENSIONS GIVEN ARE IN INCHES

SEE DRAWING D-3 FOR LOCATION OF SYMBOLS L, P, T &amp; W



A36

E70

50

## DATA SHEET - LONGITUDINAL FILLET WELDS

 $W = 1/4"$ 

SPECIMEN NO.	GAUGE LENGTH	L1	L2	P	T	W	LOAD KIPS
W374A	1.96	.47	.54	.36	.36	.38	182.5
	1.93	.55	.57	.40	.40	.38	
	1.96	.53	.58	.40	.40	.39	
	1.95	.53	.55	.38	.38	.39	
<b>Average or Total</b>	7.80	.52	.56	.39	.39	.39	
W374B	2.00	.64	.62	.39	.39	.37	187.0
	2.01	.56	.61	.38	.39	.38	
	1.99	.63	.55	.37	.37	.36	
	1.99	.54	.65	.39	.39	.39	
<b>Average or Total</b>	7.99	.59	.61	.38	.39	.38	
W374C	1.98	.62	.49	.38	.38	.38	187.0
	2.01	.54	.58	.39	.39	.36	
	2.01	.53	.52	.37	.37	.37	
	2.00	.58	.55	.39	.42	.40	
<b>Average or Total</b>	8.00	.57	.53	.38	.39	.38	

NOTES: DIMENSIONS GIVEN ARE IN INCHES

SEE DRAWING D-3 FOR LOCATION OF SYMBOLS L, P, T &amp; W

A36  
E90  
1/4"

DATA SHEET - LONGITUDINAL FILLET WELDS

SPECIMEN NO.	GAUGE LENGTH	L1	L2	P	T	W	LOAD KIPS
W392A	1.95	.31	.34	.21	.23	.25	117.5
	1.98	.32	.33	.23	.23	.23	
	1.97	.34	.33	.23	.23	.19	
	1.95	.33	.32	.22	.23	.20	
<b>Average or Total</b>	7.85	.33	.33	.22	.23	.22	
W392B	2.00	.35	.35	.21	.22	.20	129.5
	1.99	.33	.34	.20	.19	.22	
	1.93	.33	.33	.22	.22	.24	
	1.98	.31	.31	.18	.20	.22	
<b>Average or Total</b>	7.90	.33	.33	.20	.21	.22	
W392C	2.02	.33	.33	.22	.23	.22	125.0
	1.98	.36	.36	.20	.25	.23	
	1.93	.30	.31	.23	.23	.23	
	1.99	.32	.37	.21	.23	.22	
<b>Average or Total</b>	7.92	.33	.34	.22	.24	.23	

NOTES: DIMENSIONS GIVEN ARE IN INCHES  
SEE DRAWING D-3 FOR LOCATION OF SYMBOLS L, P, T & W

A441  
E 70  
1/4"

**DATA SHEET - LONGITUDINAL FILLET WELDS**

SPECIMEN NO.	GAUGE LENGTH	L 1	L 2	P	T	W	LOAD KIPS
W472A	1.97	.31	.31	.26	.24	.22	117.0
	2.00	.31	.35	.26	.26	.21	
	2.01	.32	.30	.24	.24	.22	
	2.03	.31	.34	.27	.27	.21	
<b>Average or Total</b>	<b>8.01</b>	<b>.31</b>	<b>.33</b>	<b>.26</b>	<b>.25</b>	<b>.22</b>	
W472B	1.96	.33	.31	.23	.23	.22	111.0
	1.98	.34	.33	.23	.23	.19	
	2.04	.33	.32	.23	.23	.20	
	2.00	.32	.30	.22	.22	.21	
<b>Average or Total</b>	<b>7.98</b>	<b>.33</b>	<b>.32</b>	<b>.23</b>	<b>.23</b>	<b>.21</b>	
W472C	1.98	.30	.32	.23	.23	.21	115.0
	2.01	.30	.30	.22	.23	.23	
	1.98	.30	.34	.22	.23	.24	
	2.00	.32	.32	.25	.22	.23	
<b>Average or Total</b>	<b>7.97</b>	<b>.31</b>	<b>.32</b>	<b>.23</b>	<b>.23</b>	<b>.23</b>	

**NOTES:** DIMENSIONS GIVEN ARE IN INCHES  
SEE DRAWING D-3 FOR LOCATION OF SYMBOLS L, P, T & W

A441  
E70  
3/8

DATA SHEET - LONGITUDINAL FILLET WELDS

SPECIMEN NO.	GAUGE LENGTH	L1	L2	P	T	W	LOAD KIPS
W473A	1.96	.47	.44	.32	.32	.30	153.0
	1.97	.43	.43	.28	.31	.28	
	2.02	.42	.38	.28	.28	.31	
	1.98	.43	.43	.30	.30	.31	
<b>Average or Total</b>	7.93	.44	.42	.30	.30	.30	
W473B	2.03	.51	.43	.30	.33	.28	149.0
	2.04	.40	.43	.30	.30	.32	
	2.02	.46	.49	.32	.33	.31	
	2.00	.42	.43	.28	.26	.28	
<b>Average or Total</b>	8.09	.45	.45	.30	.31	.30	
W473C	1.98	.47	.44	.31	.31	.30	147.5
	1.97	.49	.50	.32	.35	.28	
	1.98	.45	.43	.30	.30	.30	
	1.97	.49	.50	.32	.35	.33	
<b>Average or Total</b>	7.90	.48	.47	.31	.33	.30	

NOTES: DIMENSIONS GIVEN ARE IN INCHES  
SEE DRAWING D-3 FOR LOCATION OF SYMBOLS L, P, T & W

A441  
E70  
1/2"

DATA SHEET - LONGITUDINAL FILLET WELDS

SPECIMEN NO.	GAUGE LENGTH	L 1	L 2	P	T	W	LOAD KIPS
W474A	1.98	.60	.60	.35	.38	.33	169.0
	1.97	.56	.65	.42	.42	.36	
	2.00	.56	.56	.36	.36	.32	
	2.00	.54	.61	.39	.39	.34	
<b>Average or Total</b>	7.95	.56	.60	.38	.39	.34	
W474B	1.95	.55	.57	.40	.37	.35	172.5
	1.99	.57	.63	.38	.38	.35	
	1.98	.54	.55	.37	.37	.32	
	1.99	.55	.62	.37	.37	.31	
<b>Average or Total</b>	7.91	.55	.59	.38	.37	.33	
W474C	1.98	.64	.46	.35	.37	.33	169.0
	1.98	.53	.48	.35	.35	.33	
	1.99	.55	.49	.37	.37	.35	
	1.97	.61	.48	.35	.37	.32	
<b>Average or Total</b>	7.92	.58	.48	.36	.37	.33	

NOTES: DIMENSIONS GIVEN ARE IN INCHES  
SEE DRAWING D-3 FOR LOCATION OF SYMBOLS L, P, T & W

A441  
E90  
1/4

DATA SHEET - LONGITUDINAL FILLET WELDS

SPECIMEN NO.	GAUGE LENGTH	L1	L2	P	T	W	LOAD KIPS
W492A	1.98	.32	.29	.22	.22	.19	104.0
	2.03	.24	.27	.18	.18	.17	
	1.98	.37	.31	.22	.24	.22	
	1.97	.23	.28	.18	.18	.20	
Average or Total	7.96	.29	.29	.20	.21	.20	
W492B	2.01	.31	.28	.21	.21	.20	116.0
	2.03	.27	.28	.20	.20	.20	
	1.96	.33	.31	.22	.22	.18	
	1.96	.27	.32	.22	.21	.20	
Average or Total	7.96	.30	.30	.21	.21	.20	
W492C	1.98	.30	.30	.22	.22	.19	112.5
	1.96	.30	.28	.21	.21	.20	
	2.01	.28	.28	.21	.21	.20	
	1.99	.30	.31	.20	.22	.22	
Average or Total	7.94	.30	.29	.21	.22	.20	

NOTES: DIMENSIONS GIVEN ARE IN INCHES  
SEE DRAWING D-3 FOR LOCATION OF SYMBOLS L, P, T & W

A441  
E90  
3/8

DATA SHEET - LONGITUDINAL FILLET WELDS

SPECIMEN NO.	GAUGE LENGTH	L 1	L 2	P	T	W	LOAD KIPS
W493A	1.96	.42	.45	.30	.30	.28	168.5
	1.97	.44	.46	.31	.32	.29	
	2.02	.40	.45	.30	.30	.30	
	1.99	.50	.46	.31	.33	.30	
<b>Average or Total</b>	7.94	.44	.46	.31	.31	.29	
W493B	1.97	.48	.42	.32	.32	.29	178.0
	1.96	.43	.44	.28	.31	.30	
	1.98	.43	.44	.32	.30	.30	
	1.98	.45	.47	.31	.33	.31	
<b>Average or Total</b>	7.89	.45	.44	.31	.31	.30	
W493C	2.01	.40	.42	.29	.29	.27	165.0
	1.96	.45	.44	.31	.31	.29	
	1.98	.37	.38	.26	.26	.29	
	2.00	.42	.43	.30	.30	.31	
<b>Average or Total</b>	7.95	.41	.42	.29	.29	.29	

NOTES: DIMENSIONS GIVEN ARE IN INCHES  
SEE DRAWING D-3 FOR LOCATION OF SYMBOLS L, P, T & W

A441  
E90  
1/2"

DATA SHEET - LONGITUDINAL FILLET WELDS

SPECIMEN NO.	GAUGE LENGTH	L1	L2	P	T	W	LOAD KIPS
W494A	1.98	.52	.50	.37	.37	.38	199.0
	1.97	.58	.49	.35	.36	.32	
	1.97	.59	.49	.36	.37	.34	
	2.01	.61	.53	.40	.40	.38	
Average or Total	7.93	.58	.50	.37	.38	.36	
W494B	1.97	.54	.50	.37	.37	.37	196.5
	1.96	.58	.51	.37	.37	.37	
	2.00	.57	.57	.40	.40	.33	
	2.00	.49	.43	.33	.33	.32	
Average or Total	7.93	.54	.50	.37	.37	.35	
W494C	1.98	.57	.48	.37	.37	.37	191.5
	1.98	.64	.48	.37	.37	.35	
	1.95	.53	.56	.40	.40	.35	
	1.96	.63	.48	.38	.38	.33	
Average or Total	7.87	.59	.50	.38	.38	.35	

NOTES: DIMENSIONS GIVEN ARE IN INCHES  
SEE DRAWING D-3 FOR LOCATION OF SYMBOLS L, P, T & W



A441  
E110  
1/4"

DATA SHEET - LONGITUDINAL FILLET WELDS

SPECIMEN NO.	GAUGE LENGTH	L1	L2	P	T	W	LOAD KIPS
W412A	2.00	.28	.30	.20	.20	.18	100.5
	2.02	.27	.28	.18	.20	.19	
	2.05	.25	.26	.18	.18	.20	
	2.02	.28	.29	.20	.20	.20	
Average or Total	8.09	.27	.28	.19	.20	.19	
W412B	1.94	.28	.30	.16	.20	.21	115.5
	1.95	.32	.33	.24	.23	.19	
	1.97	.32	.27	.18	.20	.21	
	1.99	.30	.32	.18	.22	.22	
Average or Total	7.85	.31	.31	.19	.21	.21	
W412C	1.95	.32	.30	.20	.22	.19	122.0
	2.00	.25	.29	.19	.19	.20	
	2.02	.27	.27	.19	.19	.20	
	1.99	.28	.31	.20	.20	.20	
Average or Total	7.96	.28	.29	.20	.20	.20	

NOTES: DIMENSIONS GIVEN ARE IN INCHES  
SEE DRAWING D-3 FOR LOCATION OF SYMBOLS L, P, T & W

AS14  
E70  
1/4

DATA SHEET - LONGITUDINAL FILLET WELDS

SPECIMEN NO.	GAUGE LENGTH	L1	L2	P	T	W	LOAD KIPS
W572A	1.98	.25	.25	.16	.18	.18	102.0
	1.99	.27	.27	.19	.20	.20	
	1.99	.27	.25	.18	.17	.20	
	2.00	.25	.22	.18	.18	.21	
Average or Total	7.96	.26	.25	.18	.18	.20	
W572B	2.06	.31	.31	.22	.22	.19	105.0
	2.05	.25	.27	.18	.18	.20	
	1.98	.28	.27	.19	.19	.19	
	1.99	.25	.28	.19	.19	.23	
Average or Total	8.08	.27	.28	.20	.20	.20	
W572C	1.96	.26	.24	.16	.18	.20	101.0
	1.98	.26	.24	.16	.16	.19	
	1.97	.27	.30	.19	.20	.18	
	2.00	.27	.26	.17	.19	.20	
Average or Total	7.91	.27	.26	.17	.18	.19	

NOTES: DIMENSIONS GIVEN ARE IN INCHES  
SEE DRAWING D-3 FOR LOCATION OF SYMBOLS L, P, T & W

AS14  
E70  
3/8"

DATA SHEET - LONGITUDINAL FILLET WELDS

SPECIMEN NO.	GAUGE LENGTH	L 1	L 2	P	T	W	LOAD KIPS
W573A	1.97	.43	.43	.32	.30	.31	151.0
	2.01	.43	.46	.29	.32	.28	
	1.95	.47	.45	.30	.32	.28	
	1.96	.39	.44	.30	.30	.28	
Average or Total	7.89	.43	.45	.30	.31	.29	
W573B	2.01	.47	.45	.34	.34	.28	166.0
	1.96	.45	.48	.33	.33	.28	
	1.99	.42	.53	.35	.33	.29	
	2.00	.44	.51	.36	.34	.33	
Average or Total	7.96	.45	.49	.35	.34	.30	
W573C	1.99	.48	.42	.32	.32	.30	164.0
	1.98	.46	.44	.35	.35	.30	
	1.97	.45	.53	.34	.34	.28	
	1.94	.44	.46	.35	.34	.31	
Average or Total	7.88	.46	.46	.34	.34	.30	

NOTES: DIMENSIONS GIVEN ARE IN INCHES  
SEE DRAWING D-3 FOR LOCATION OF SYMBOLS L, P, T & W

AS14  
E70  
1/2

DATA SHEET - LONGITUDINAL FILLET WELDS

SPECIMEN NO.	GAUGE LENGTH	L1	L2	P	T	W	LOAD KIPS
W574A	1.97	.53	.64	.38	.38	.31	176.5
	1.94	.55	.49	.33	.33	.29	
	2.02	.62	.50	.35	.36	.33	
	2.01	.51	.55	.33	.33	.31	
<b>Average or Total</b>	7.94	.55	.54	.35	.35	.31	
W574B	2.02	.57	.42	.37	.34	.31	173.5
	1.99	.47	.47	.34	.34	.33	
	2.03	.53	.43	.34	.34	.32	
	1.96	.45	.45	.32	.32	.30	
<b>Average or Total</b>	8.00	.51	.44	.34	.34	.32	
W574C	1.99	.50	.48	.35	.35	.31	179.0
	1.98	.56	.49	.37	.37	.36	
	1.99	.46	.53	.35	.35	.31	
	1.98	.53	.52	.37	.37	.34	
<b>Average or Total</b>	7.94	.51	.51	.36	.36	.33	

NOTES: DIMENSIONS GIVEN ARE IN INCHES  
SEE DRAWING D-3 FOR LOCATION OF SYMBOLS L, P, T & W

AS14  
E90  
1/4"

DATA SHEET - LONGITUDINAL FILLET WELDS

SPECIMEN NO.	GAUGE LENGTH	L1	L2	P	T	W	LOAD KIPS
W592A	2.01	.28	.28	.18	.19	.19	120.0
	2.01	.25	.24	.19	.18	.19	
	2.01	.31	.30	.21	.20	.23	
	2.01	.23	.26	.17	.18	.20	
Average or Total	8.04	.27	.27	.19	.19	.20	
W592B	2.01	.25	.26	.18	.18	.18	120.5
	1.99	.32	.26	.22	.20	.20	
	2.00	.30	.28	.20	.20	.20	
	1.97	.34	.30	.22	.22	.19	
Average or Total	7.97	.30	.28	.21	.20	.19	
W592C	1.99	.28	.26	.22	.20	.20	119.0
	1.99	.25	.28	.20	.20	.20	
	1.97	.28	.28	.20	.20	.21	
	1.98	.30	.27	.20	.20	.22	
Average or Total	7.93	.28	.27	.21	.20	.21	

NOTES: DIMENSIONS GIVEN ARE IN INCHES  
SEE DRAWING D-3 FOR LOCATION OF SYMBOLS L, P, T & W

AS14  
E90  
3/8"

DATA SHEET - LONGITUDINAL FILLET WELDS

SPECIMEN NO.	GAUGE LENGTH	L 1	L 2	P	T	W	LOAD KIPS
W593A	1.99	.48	.45	.32	.33	.29	179.0
	1.96	.47	.45	.32	.32	.29	
	1.98	.45	.49	.33	.33	.28	
	1.98	.48	.46	.34	.32	.30	
<b>Average or Total</b>	7.91	.47	.46	.33	.33	.29	
W593B	2.00	.46	.43	.30	.30	.28	178.0
	1.98	.49	.51	.30	.33	.30	
	1.98	.53	.40	.31	.30	.31	
	1.98	.46	.49	.28	.32	.30	
<b>Average or Total</b>	7.94	.49	.46	.30	.31	.30	
W593C	1.96	.39	.45	.30	.30	.29	181.5
	1.97	.45	.44	.32	.32	.27	
	1.99	.49	.39	.30	.30	.28	
	2.00	.45	.45	.33	.33	.30	
<b>Average or Total</b>	7.92	.45	.43	.31	.31	.29	

NOTES: DIMENSIONS GIVEN ARE IN INCHES  
SEE DRAWING D-3 FOR LOCATION OF SYMBOLS L, P, T & W

AS14  
E90  
1/24

DATA SHEET - LONGITUDINAL FILLET WELDS

SPECIMEN NO.	GAUGE LENGTH	L1	L2	P	T	W	LOAD KIPS
W594A	2.01	.53	.57	.36	.36	.33	200.0
	2.00	.55	.58	.36	.36	.34	
	2.00	.50	.51	.32	.31	.32	
	2.03	.50	.60	.34	.34	.31	
Average or Total	8.04	.52	.56	.35	.34	.33	
W594B	2.00	.61	.61	.34	.34	.31	199.0
	1.95	.59	.56	.33	.34	.34	
	1.97	.52	.59	.35	.35	.33	
	1.93	.56	.58	.36	.37	.33	
Average or Total	7.85	.57	.58	.35	.35	.33	
W594C	1.97	.55	.45	.33	.34	.33	199.0
	1.95	.59	.48	.36	.36	.33	
	1.95	.53	.51	.36	.36	.38	
	1.98	.49	.47	.33	.33	.34	
Average or Total	7.85	.54	.48	.35	.35	.35	

NOTES: DIMENSIONS GIVEN ARE IN INCHES  
SEE DRAWING D-3 FOR LOCATION OF SYMBOLS L, P, T & W

AS14  
E110  
1/4"

DATA SHEET - LONGITUDINAL FILLET WELDS

SPECIMEN NO.	GAUGE LENGTH	L1	L2	P	T	W	LOAD KIPS
W512A	1.98	.30	.27	.18	.18.	.20	125.5
	2.01	.23	.28	.18	.18	.18	
	2.01	.28	.28	.20	.20	.28	
	2.01	.28	.29	.20	.20	.20	
<b>Average or Total</b>	8.01	.27	.28	.19	.19	.22	
W512B	1.96	.26	.29	.19	.19	.19	126.5
	1.94	.25	.27	.18	.19	.21	
	1.97	.27	.27	.17	.18	.19	
	1.99	.25	.28	.17	.19	.18	
<b>Average or Total</b>	7.86	.26	.28	.18	.19	.19	
W512C	1.98	.35	.33	.21	.22	.22	129.5
	2.00	.29	.32	.22	.20	.19	
	1.99	.29	.29	.20	.20	.20	
	2.01	.26	.26	.19	.19	.19	
<b>Average or Total</b>	7.98	.30	.30	.21	.20	.20	

NOTES: DIMENSIONS GIVEN ARE IN INCHES  
SEE DRAWING D-3 FOR LOCATION OF SYMBOLS L, P, T & W



AS14  
E110  
3/8"

DATA SHEET - LONGITUDINAL FILLET WELDS

SPECIMEN NO.	GAUGE LENGTH	L 1	L 2	P	T	W	LOAD KIPS
W513A	1.88	.48	.45	.29	.31	.29	170.0
	1.89	.47	.43	.28	.30	.34	
	1.89	.50	.40	.29	.29	.30	
	1.92	.49	.46	.30	.31	.29	
Average or Total	7.58	.49	.44	.29	.30	.31	
W513B	1.96	.44	.43	.30	.30	.28	190.5
	1.94	.38	.47	.29	.29	.31	
	1.84	.48	.48	.34	.34	.30	
	1.89	.40	.44	.32	.30	.32	
Average or Total	7.63	.43	.46	.31	.31	.30	
W513C	1.98	.41	.48	.32	.32	.31	188.5
	1.94	.47	.42	.30	.30	.29	
	1.91	.48	.48	.32	.35	.30	
	1.89	.43	.43	.30	.30	.34	
Average or Total	7.72	.45	.45	.31	.32	.31	

NOTES: DIMENSIONS GIVEN ARE IN INCHES  
SEE DRAWING D-3 FOR LOCATION OF SYMBOLS L, P, T & W

AS14  
E110  
1/2"

DATA SHEET - LONGITUDINAL FILLET WELDS

SPECIMEN NO.	GAUGE LENGTH	L1	L2	P	T	W	LOAD KIPS
W514A	2.02	.56	.49	.37	.37	.35	229.0
	1.97	.55	.51	.37	.37	.38	
	1.98	.53	.46	.34	.34	.36	
	1.98	.60	.46	.37	.37	.35	
<b>Average or Total</b>	7.95	.56	.48	.36	.36	.36	
W514B	1.99	.57	.52	.38	.38	.39	234.0
	1.99	.52	.48	.35	.35	.40	
	1.95	.55	.48	.35	.35	.34	
	1.98	.53	.43	.33	.33	.33	
<b>Average or Total</b>	7.91	.54	.48	.35	.35	.37	
W514C	1.98	.60	.43	.37	.37	.38	239.0
	2.00	.57	.43	.35	.35	.32	
	1.99	.53	.50	.34	.34	.35	
	2.00	.50	.55	.33	.36	.37	
<b>Average or Total</b>	7.97	.55	.48	.35	.36	.36	

NOTES: DIMENSIONS GIVEN ARE IN INCHES  
SEE DRAWING D-3 FOR LOCATION OF SYMBOLS L, P, T & W

A36  
E60  
1/4"

DATA SHEET - LONGITUDINAL FILLET WELDS

$w = 1/4"$

SPECIMEN NO.	GAUGE LENGTH	L1	L2	P	T	W	LOAD KIPS
E362A	1.92	.26	.30	.24	.20	.27	105.0
	1.92	.23	.36	.22	.18	.26	
	1.97	.25	.29	.24	.20	.28	
	1.99	.25	.28	.24	.21	.30	
Average or Total	7.80	.25	.31	.24	.20	.28	
E362B	1.89	.29	.26	.23	.20	.27	98.5
	1.85	.23	.28	.20	.18	.24	
	1.94	.32	.33	.23	.23	.25	
	1.94	.25	.26	.21	.17	.24	
Average or Total	7.62	.27	.28	.22	.20	.25	
E362C	1.94	.24	.25	.22	.19	.25	109.0
	1.89	.25	.25	.25	.22	.25	
	1.98	.26	.30	.25	.22	.26	
	2.01	.28	.29	.27	.22	.24	
Average or Total	7.82	.26	.27	.25	.21	.25	

NOTES: DIMENSIONS GIVEN ARE IN INCHES  
SEE DRAWING D-3 FOR LOCATION OF SYMBOLS L, P, T & W

A36  
E60  
3/8

DATA SHEET - LONGITUDINAL FILLET WELDS *WEL = 3/8"*

SPECIMEN NO.	GAUGE LENGTH	L1	L2	P	T	W	LOAD KIPS
E363A	1.94	.40	.45	.30	.30	.34	123.0
	1.95	.49	.42	.28	.28	.32	
	1.90	.37	.45	.28	.29	.37	
	1.94	.39	.40	.28	.28	.29	
<b>Average or Total</b>	7.73	.41	.43	.29	.29	.33	
E363B	1.95	.34	.47	.31	.29	.33	129.0
	1.95	.45	.37	.30	.29	.33	
	2.02	.36	.50	.31	.30	.33	
	1.95	.39	.41	.31	.30	.32	
<b>Average or Total</b>	7.87	.39	.44	.31	.30	.33	
E363C	1.92	.35	.37	.28	.26	.30	123.0
	1.97	.33	.47	.28	.28	.33	
	1.96	.33	.36	.26	.25	.27	
	1.95	.39	.45	.29	.28	.25	
<b>Average or Total</b>	7.80	.35	.41	.28	.27	.29	

NOTES: DIMENSIONS GIVEN ARE IN INCHES  
SEE DRAWING D-3 FOR LOCATION OF SYMBOLS L, P, T & W

A36  
E70  
1/4"

DATA SHEET - LONGITUDINAL FILLET WELDS

SPECIMEN NO.	GAUGE LENGTH	L1	L2	P	T	W	LOAD KIPS
<b>E372A</b>	1.93	.32	.30	.24	.24	.28	117.0
	1.92	.29	.31	.25	.21	.25	
	1.94	.33	.29	.22	.22	.26	
	1.96	.28	.30	.25	.20	.22	
<b>Average or Total</b>	7.75	.31	.30	.24	.22	.25	
<b>E372B</b>	1.96	.29	.32	.25	.22	.26	119.0
	1.99	.31	.28	.23	.21	.25	
	1.92	.29	.31	.24	.22	.24	
	1.92	.32	.24	.21	.21	.27	
<b>Average or Total</b>	7.79	.30	.29	.23	.22	.26	
<b>E372C</b>	1.96	.35	.31	.25	.23	.25	110.5
	1.93	.31	.28	.20	.21	.25	
	1.95	.34	.25	.20	.20	.24	
	1.96	.28	.25	.21	.19	.25	
<b>Average or Total</b>	7.80	.32	.27	.22	.21	.25	

NOTES: DIMENSIONS GIVEN ARE IN INCHES  
SEE DRAWING D-3 FOR LOCATION OF SYMBOLS L, P, T & W

A 36  
E 70  
3/8

DATA SHEET - LONGITUDINAL FILLET WELDS

SPECIMEN NO.	GAUGE LENGTH	L 1	L 2	P	T	W	LOAD KIPS
E373A	1.96	.40	.54	.32	.31	.35	159.0
	1.95	.47	.43	.34	.33	.38	
	1.98	.43	.41	.35	.31	.35	
	1.97	.49	.41	.34	.32	.35	
Average or Total	7.86	.45	.45	.34	.32	.36	
E373B	1.95	.45	.43	.34	.32	.41	155.0
	1.96	.45	.36	.33	.33	.38	
	1.94	.43	.46	.35	.30	.38	
	1.95	.43	.42	.35	.31	.38	
Average or Total	7.80	.44	.42	.34	.32	.39	
E373C	1.98	.42	.50	.36	.32	.36	163.0
	1.98	.50	.41	.33	.32	.40	
	1.99	.39	.55	.35	.33	.35	
	1.97	.44	.45	.32	.32	.35	
Average or Total	7.92	.44	.48	.34	.32	.37	

NOTES: DIMENSIONS GIVEN ARE IN INCHES  
SEE DRAWING D-3 FOR LOCATION OF SYMBOLS L, P, T & W

A36  
E70  
1/2"

DATA SHEET - LONGITUDINAL FILLET WELDS

SPECIMEN NO.	GAUGE LENGTH	L1	L2	P	T	W	LOAD KIPS
E374A	1.88	.45	.54	.46	.37	.41	183.0
	1.92	.49	.57	.41	.37	.39	
	1.99	.43	.60	.39	.35	.36	
	2.00	.51	.57	.42	.37	.43	
<b>Average or Total</b>	<b>7.79</b>	<b>.47</b>	<b>.57</b>	<b>.42</b>	<b>.37</b>	<b>.40</b>	
E374B	1.98	.49	.57	.45	.37	.39	187.5
	1.96	.45	.46	.39	.32	.42	
	1.99	.52	.59	.41	.38	.40	
	1.98	.49	.60	.41	.38	.41	
<b>Average or Total</b>	<b>7.91</b>	<b>.49</b>	<b>.56</b>	<b>.42</b>	<b>.36</b>	<b>.41</b>	
E374C	1.95	.50	.57	.45	.38	.42	191.0
	1.96	.59	.62	.45	.43	.46	
	1.93	.50	.62	.42	.39	.44	
	1.92	.51	.50	.41	.38	.43	
<b>Average or Total</b>	<b>7.76</b>	<b>.52</b>	<b>.58</b>	<b>.43</b>	<b>.40</b>	<b>.44</b>	

NOTES: DIMENSIONS GIVEN ARE IN INCHES  
SEE DRAWING D-3 FOR LOCATION OF SYMBOLS L, P, T & W

## DATA SHEET - LONGITUDINAL FILLET WELDS

SPECIMEN NO.	GAUGE LENGTH	L 1	L 2	P	T	W	LOAD KIPS
E392A	1.96	.30	.35	.28	.23	.26	123.0
	2.00	.29	.35	.22	.20	.25	
	1.94	.29	.25	.27	.21	.28	
	1.97	.35	.25	.25	.20	.26	
Average or Total	7.87	.21	.30	.26	.21	.26	
E392B	1.94	.31	.36	.26	.25	.28	131.0
	1.97	.34	.25	.26	.22	.26	
	1.90	.27	.32	.25	.22	.29	
	1.94	.33	.29	.27	.22	.25	
Average or Total	7.75	.31	.31	.26	.23	.27	
E392C	1.96	.31	.31	.27	.24	.26	131.5
	1.97	.31	.27	.24	.21	.25	
	1.96	.31	.25	.21	.21	.27	
	1.96	.29	.26	.24	.20	.25	
Average or Total	7.85	.31	.27	.24	.22	.26	

NOTES: DIMENSIONS GIVEN ARE IN INCHES  
SEE DRAWING D-3 FOR LOCATION OF SYMBOLS L, P, T & W



## DATA SHEET - LONGITUDINAL FILLET WELDS

SPECIMEN NO.	GAUGE LENGTH	L 1	L 2	P	T	W	LOAD KIPS
E472A	1.95	.30	.29	.22	.22	.26	121.0
	1.98	.29	.30	.22	.21	.26	
	1.94	.29	.28	.21	.20	.25	
	1.94	.26	.28	.24	.20	.26	
<b>Average or Total</b>	7.81	.29	.29	.22	.21	.26	
E472B	1.97	.32	.26	.22	.20	.25	121.0
	1.98	.28	.32	.25	.22	.26	
	1.98	.32	.23	.20	.19	.23	
	2.01	.32	.30	.23	.22	.28	
<b>Average or Total</b>	7.94	.31	.28	.23	.21	.26	
E472C	1.95	.35	.29	.24	.23	.27	123.5
	1.97	.35	.31	.26	.25	.26	
	1.98	.29	.31	.25	.21	.24	
	1.99	.29	.30	.22	.22	.25	
<b>Average or Total</b>	7.89	.32	.30	.24	.23	.26	

NOTES: DIMENSIONS GIVEN ARE IN INCHES  
SEE DRAWING D-3 FOR LOCATION OF SYMBOLS L, P, T & W

## DATA SHEET - LONGITUDINAL FILLET WELDS

SPECIMEN NO.	GAUGE LENGTH	L 1	L 2	P	T	W	LOAD KIPS
E473A	1.88	.50	.39	.32	.31	.38	167.0
	1.88	.54	.48	.35	.35	.36	
	1.93	.45	.48	.33	.33	.36	
	1.98	.48	.43	.33	.32	.36	
Average or Total	7.67	.49	.45	.33	.33	.37	
E473B	1.94	.55	.43	.36	.32	.42	167.0
	1.95	.40	.41	.35	.30	.38	
	1.93	.55	.41	.36	.33	.36	
	1.96	.38	.32	.35	.27	.37	
Average or Total	7.78	.47	.39	.36	.31	.38	
E473C	1.96	.41	.50	.36	.32	.36	172.0
	1.95	.46	.40	.35	.32	.37	
	1.94	.40	.50	.36	.32	.37	
	1.91	.53	.43	.40	.34	.38	
Average or Total	7.76	.45	.46	.37	.33	.37	

NOTES: DIMENSIONS GIVEN ARE IN INCHES  
SEE DRAWING D-3 FOR LOCATION OF SYMBOLS L, P, T & W

## DATA SHEET - LONGITUDINAL FILLET WELDS

SPECIMEN NO.	GAUGE LENGTH	L 1	L 2	P	T	W	LOAD KIPS
E474A	1.97	.47	.57	.41	.37	.43	192.0
	1.97	.54	.56	.42	.39	.42	
	2.00	.52	.58	.42	.38	.37	
	1.98	.46	.55	.42	.36	.42	
Average or Total	7.92	.50	.56	.42	.38	.41	
E474B	1.94	.47	.65	.46	.39	.42	190.0
	1.96	.47	.49	.39	.35	.42	
	1.92	.46	.58	.40	.37	.42	
	1.92	.53	.55	.45	.39	.42	
Average or Total	7.74	.48	.57	.43	.38	.42	
E474C	1.95	.49	.59	.40	.38	.39	185.5
	1.95	.56	.59	.43	.40	.39	
	1.94	.47	.61	.37	.37	.44	
	1.92	.51	.54	.42	.39	.39	
Average or Total	7.76	.51	.58	.41	.39	.40	

NOTES: DIMENSIONS GIVEN ARE IN INCHES  
SEE DRAWING D-3 FOR LOCATION OF SYMBOLS L, P, T & W

## DATA SHEET - LONGITUDINAL FILLET WELDS

SPECIMEN NO.	GAUGE LENGTH	L 1	L 2	P	T	W	LOAD KIPS
E492A	1.96	.33	.34	.28	.24	.27	136.5
	1.98	.31	.31	.24	.22	.29	
	1.90	.34	.31	.25	.22	.29	
	1.93	.30	.33	.26	.21	.27	
Average or Total	7.77	.32	.32	.26	.22	.28	
E492B	2.00	.31	.31	.27	.23	.26	134.5
	1.97	.33	.27	.25	.21	.26	
	2.02	.28	.30	.25	.21	.27	
	2.00	.30	.32	.26	.23	.27	
Average or Total	7.99	.31	.30	.26	.22	.27	
E492C	1.97	.33	.25	.22	.20	.25	129.5
	1.94	.34	.29	.21	.19	.28	
	1.97	.29	.34	.23	.18	.27	
	1.96	.30	.34	.22	.20	.27	
Average or Total	7.84	.32	.31	.22	.19	.27	

NOTES: DIMENSIONS GIVEN ARE IN INCHES  
SEE DRAWING D-3 FOR LOCATION OF SYMBOLS L, P, T & W

## DATA SHEET - LONGITUDINAL FILLET WELDS

SPECIMEN NO.	GAUGE LENGTH	L 1	L 2	P	T	W	LOAD KIPS
<b>E493A</b>	1.95	.38	.37	.32	.29	.33	171.5
	1.92	.34	.42	.33	.26	.30	
	1.97	.33	.43	.33	.26	.34	
	1.97	.32	.42	.30	.25	.33	
<b>Average or Total</b>	7.81	.34	.41	.32	.26	.33	
<b>E493B</b>	1.97	.42	.40	.30	.27	.32	171.5
	1.97	.40	.38	.34	.25	.36	
	1.97	.35	.43	.31	.25	.32	
	1.95	.41	.41	.31	.27	.33	
<b>Average or Total</b>	7.86	.40	.41	.32	.26	.33	
<b>E493C</b>	1.96	.41	.37	.35	.30	.34	168.0
	1.96	.38	.35	.33	.28	.33	
	1.94	.33	.37	.30	.29	.31	
	1.94	.41	.38	.32	.31	.33	
<b>Average or Total</b>	7.80	.38	.37	.33	.30	.33	

NOTES: DIMENSIONS GIVEN ARE IN INCHES  
SEE DRAWING D-3 FOR LOCATION OF SYMBOLS L, P, T & W

## DATA SHEET - LONGITUDINAL FILLET WELDS

SPECIMEN NO.	GAUGE LENGTH	L 1	L 2	P	T	W	LOAD KIPS
E494A	1.94	.34	.50	.37	.29	.43	199.0
	1.88	.39	.51	.37	.30	.42	
	1.92	.41	.51	.38	.32	.41	
	1.95	.34	.37	.34	.36	.43	
Average or Total	7.69	.37	.47	.37	.32	.42	
E494B	1.97	.46	.46	.40	.34	.44	200.0
	1.95	.39	.43	.38	.30	.42	
	1.97	.49	.45	.42	.33	.41	
	1.93	.36	.50	.37	.31	.43	
Average or Total	7.82	.43	.46	.39	.32	.43	
E494C	1.96	.45	.46	.39	.33	.42	204.5
	1.93	.36	.50	.38	.30	.48	
	1.97	.48	.48	.43	.33	.44	
	1.99	.40	.45	.39	.31	.42	
Average or Total	7.85	.42	.47	.40	.32	.44	

NOTES: DIMENSIONS GIVEN ARE IN INCHES  
SEE DRAWING D-3 FOR LOCATION OF SYMBOLS L, P, T & W

## DATA SHEET - LONGITUDINAL FILLET WELDS

SPECIMEN NO.	GAUGE LENGTH	L 1	L 2	P	T	W	LOAD KIPS
E412A	1.93	.29	.28	.24	.21	.28	146.5
	1.92	.32	.30	.25	.23	.25	
	1.94	.34	.30	.24	.23	.26	
	1.93	.28	.36	.26	.24	.28	
Average or Total	7.72	.31	.31	.25	.23	.27	
E412B	1.96	.32	.27	.22	.20	.27	148.0
	1.94	.29	.30	.21	.21	.26	
	2.00	.32	.32	.23	.23	.24	
	1.98	.30	.26	.22	.21	.26	
Average or Total	7.88	.31	.29	.22	.21	.26	
E412C	1.90	.29	.31	.25	.20	.28	150.5
	1.92	.34	.29	.26	.21	.25	
	1.95	.27	.31	.23	.18	.31	
	1.95	.34	.25	.27	.22	.25	
Average or Total	7.72	.31	.29	.25	.20	.27	

NOTES: DIMENSIONS GIVEN ARE IN INCHES  
SEE DRAWING D-3 FOR LOCATION OF SYMBOLS L, P, T & W

## DATA SHEET - LONGITUDINAL FILLET WELDS

SPECIMEN NO.	GAUGE LENGTH	L 1	L 2	P	T	W	LOAD KIPS
E572A	1.92	.32	.23	.22	.22	.27	124.0
	1.89	.33	.26	.21	.21	.22	
	1.94	.34	.27	.22	.21	.26	
	2.02	.32	.30	.24	.23	.26	
Average or Total	7.77	.33	.27	.22	.22	.25	
E572B	1.97	.32	.30	.23	.22	.25	130.5
	1.93	.29	.26	.22	.19	.25	
	1.93	.34	.26	.20	.20	.26	
	1.92	.32	.28	.22	.21	.25	
Average or Total	7.75	.32	.28	.22	.21	.25	
E572C	1.95	.34	.28	.22	.21	.24	122.0
	1.92	.33	.28	.22	.21	.24	
	1.94	.30	.26	.21	.21	.25	
	1.92	.29	.27	.21	.21	.25	
Average or Total	7.73	.32	.27	.22	.21	.25	

NOTES: DIMENSIONS GIVEN ARE IN INCHES  
SEE DRAWING D-3 FOR LOCATION OF SYMBOLS L, P, T & W



## DATA SHEET - LONGITUDINAL FILLET WELDS

SPECIMEN NO.	GAUGE LENGTH	L 1	L 2	P	T	W	LOAD KIPS
E573A	1.93	.36	.36	.26	.26	.34	163.0
	1.96	.35	.36	.28	.25	.32	
	1.98	.35	.33	.27	.25	.29	
	2.01	.36	.40	.30	.26	.32	
Average or Total	7.88	.36	.36	.28	.26	.32	
E573B	1.91	.35	.37	.30	.26	.35	162.5
	1.94	.38	.36	.30	.27	.38	
	2.02	.40	.35	.28	.27	.33	
	1.95	.39	.36	.33	.27	.32	
Average or Total	7.82	.38	.36	.30	.27	.35	
E573C	1.97	.35	.39	.27	.26	.31	163.0
	1.97	.37	.37	.28	.27	.34	
	1.98	.34	.41	.31	.28	.32	
	1.97	.39	.39	.30	.28	.35	
Average or Total	7.89	.36	.39	.29	.27	.33	

NOTES: DIMENSIONS GIVEN ARE IN INCHES  
SEE DRAWING D-3 FOR LOCATION OF SYMBOLS L, P, T & W

## DATA SHEET - LONGITUDINAL FILLET WELDS

SPECIMEN NO.	GAUGE LENGTH	L 1	L 2	P	T	W	LOAD KIPS
E574A	1.95	.52	.56	.38	.38	.36	202.0
	1.94	.47	.55	.40	.37	.36	
	1.96	.44	.57	.36	.36	.40	
	1.94	.47	.48	.36	.36	.37	
Average or Total	7.79	.48	.54	.38	.37	.37	
E574B	1.95	.40	.58	.35	.33	.37	208.0
	1.95	.45	.52	.40	.36	.38	
	1.97	.49	.59	.40	.37	.38	
	1.98	.46	.58	.40	.36	.36	
Average or Total	7.85	.45	.57	.39	.36	.37	
E574C	1.92	.50	.64	.41	.41	.42	190.0
	1.90	.42	.56	.42	.35	.39	
	1.97	.42	.59	.37	.35	.38	
	1.98	.52	.59	.43	.40	.36	
Average or Total	7.77	.47	.60	.41	.38	.39	

NOTES: DIMENSIONS GIVEN ARE IN INCHES  
SEE DRAWING D-3 FOR LOCATION OF SYMBOLS L, P, T & W

## DATA SHEET -- LONGITUDINAL FILLET WELDS

SPECIMEN NO.	GAUGE LENGTH	L 1	L 2	P	T	W	LOAD KIPS
E592A	1.89	.28	.30	.24	.21	.27	147.0
	1.92	.31	.34	.24	.24	.32	
	1.90	.30	.27	.24	.20	.24	
	1.92	.32	.35	.22	.22	.29	
Average or Total	7.63	.30	.32	.24	.22	.28	
E592B	1.94	.29	.31	.22	.21	.28	143.0
	1.93	.26	.30	.22	.21	.27	
	1.94	.28	.32	.23	.22	.26	
	1.96	.24	.26	.22	.18	.30	
Average or Total	7.77	.27	.30	.22	.21	.28	
E592C	1.97	.35	.34	.24	.24	.26	148.0
	1.94	.26	.27	.23	.20	.26	
	1.95	.33	.28	.23	.21	.26	
	1.94	.35	.30	.26	.23	.27	
Average or Total	7.80	.32	.30	.24	.22	.26	

NOTES: DIMENSIONS GIVEN ARE IN INCHES  
SEE DRAWING D-3 FOR LOCATION OF SYMBOLS L, P, T & W

## DATA SHEET - LONGITUDINAL FILLET WELDS

SPECIMEN NO.	GAUGE LENGTH	L 1	L 2	P	T	W	LOAD KIPS
E593A	1.90	.42	.39	.30	.27	.35	182.5
	1.91	.38	.45	.33	.30	.31	
	1.96	.43	.39	.33	.28	.31	
	1.92	.39	.43	.32	.30	.30	
Average or Total	7.69	.41	.42	.32	.29	.32	
E593B	1.94	.39	.39	.31	.27	.36	184.5
	1.90	.38	.43	.28	.28	.33	
	1.97	.41	.36	.30	.28	.35	
	2.00	.41	.41	.34	.28	.29	
Average or Total	7.81	.40	.40	.31	.28	.33	
E593C	2.00	.39	.39	.31	.28	.33	187.5
	2.01	.35	.41	.33	.28	.31	
	1.99	.48	.37	.33	.29	.36	
	1.96	.40	.41	.31	.29	.31	
Average or Total	7.96	.41	.40	.32	.29	.33	

NOTES: DIMENSIONS GIVEN ARE IN INCHES

SEE DRAWING D-3 FOR LOCATION OF SYMBOLS L, P, T & W

## DATA SHEET - LONGITUDINAL FILLET WELDS

SPECIMEN NO.	GAUGE LENGTH	L1	L2	P	T	W	LOAD KIPS
E594A	1.91	.42	.55	.40	.35	.44	238.0
	1.93	.45	.60	.42	.39	.40	
	1.96	.42	.45	.40	.38	.42	
	1.95	.40	.44	.42	.38	.42	
<b>Average or Total</b>	7.75	.42	.51	.41	.38	.42	
E594B	1.91	.41	.62	.40	.34	.40	235.0
	1.98	.50	.55	.40	.38	.43	
	1.94	.45	.60	.38	.37	.48	
	1.96	.49	.57	.38	.37	.42	
<b>Average or Total</b>	7.79	.46	.58	.39	.37	.43	
E594C	1.92	.49	.68	.45	.40	.41	237.0
	1.95	.44	.56	.42	.36	.41	
	1.90	.48	.63	.43	.40	.39	
	1.98	.49	.68	.43	.40	.44	
<b>Average or Total</b>	7.75	.48	.64	.43	.39	.41	

NOTES: DIMENSIONS GIVEN ARE IN INCHES  
SEE DRAWING D-3 FOR LOCATION OF SYMBOLS L, P, T & W

## DATA SHEET - LONGITUDINAL FILLET WELDS

SPECIMEN NO.	GAUGE LENGTH	L 1	L 2	P	T	W	LOAD KIPS
E512A	1.91	.31	.32	.26	.23	.27	166.0
	1.95	.34	.30	.25	.24	.28	
	1.96	.32	.25	.24	.21	.28	
	1.97	.31	.27	.25	.22	.28	
Average or Total	7.79	.32	.29	.25	.23	.28	
E512B	1.96	.32	.30	.27	.24	.31	163.0
	1.97	.34	.31	.26	.22	.27	
	1.90	.29	.32	.28	.22	.29	
	1.97	.33	.29	.27	.22	.26	
Average or Total	7.80	.32	.31	.27	.23	.28	
E512C	1.98	.29	.29	.25	.21	.26	164.0
	1.94	.29	.31	.23	.22	.26	
	1.96	.29	.28	.21	.21	.27	
	1.98	.30	.27	.21	.20	.26	
Average or Total	7.86	.29	.29	.23	.21	.26	

NOTES: DIMENSIONS GIVEN ARE IN INCHES  
SEE DRAWING D-3 FOR LOCATION OF SYMBOLS L, P, T & W

## DATA SHEET - LONGITUDINAL FILLET WELDS

SPECIMEN NO.	GAUGE LENGTH	L 1	L 2	P	T	W	LOAD KIPS
E513A	1.94	.34	.44	.30	.28	.34	213.5
	2.00	.38	.39	.30	.28	.34	
	1.91	.30	.40	.30	.26	.34	
	1.92	.37	.38	.30	.27	.41	
<b>Average or Total</b>	<b>7.77</b>	<b>.35</b>	<b>.40</b>	<b>.30</b>	<b>.27</b>	<b>.36</b>	
E513B	1.94	.35	.37	.32	.27	.34	215.5
	1.97	.39	.40	.32	.29	.38	
	1.94	.39	.44	.32	.28	.34	
	1.96	.39	.36	.32	.26	.37	
<b>Average or Total</b>	<b>7.81</b>	<b>.38</b>	<b>.39</b>	<b>.32</b>	<b>.28</b>	<b>.36</b>	
E513C	1.97	.36	.34	.28	.25	.30	212.5
	1.95	.34	.34	.28	.25	.33	
	1.92	.38	.40	.27	.27	.30	
	1.97	.43	.35	.29	.27	.33	
<b>Average or Total</b>	<b>7.81</b>	<b>.38</b>	<b>.36</b>	<b>.28</b>	<b>.26</b>	<b>.32</b>	

NOTES: DIMENSIONS GIVEN ARE IN INCHES  
SEE DRAWING D-3 FOR LOCATION OF SYMBOLS L, P, T & W

## DATA SHEET - LONGITUDINAL FILLET WELDS

SPECIMEN NO.	GAUGE LENGTH	L 1	L 2	P	T	W	LOAD KIPS
E514A	2.01	.46	.73	.39	.39	.42	274.5
	1.98	.58	.51	.42	.38	.41	
	2.00	.67	.43	.40	.38	.46	
	1.97	.51	.51	.42	.37	.43	
Average or Total	7.96	.56	.54	.41	.38	.43	
E514B	2.00	.52	.65	.41	.41	.45	283.0
	1.96	.49	.55	.41	.38	.44	
	2.01	.49	.70	.41	.40	.43	
	1.98	.51	.55	.41	.39	.39	
Average or Total	7.95	.50	.61	.41	.40	.43	
E514C	1.98	.45	.64	.38	.38	.42	270.0
	1.93	.44	.54	.39	.36	.42	
	1.97	.50	.65	.43	.41	.44	
	1.96	.46	.64	.38	.38	.44	
Average or Total	7.84	.46	.62	.40	.38	.43	

NOTES: DIMENSIONS GIVEN ARE IN INCHES  
SEE DRAWING D-3 FOR LOCATION OF SYMBOLS L, P, T & W



TABLE 2 - TRANSVERSE FILLET WELD TESTS

SCHEDULE OF MATERIAL - ELECTRODE COMBINATIONS  
AND IDENTIFICATION NUMBERS  
ALL WELDS 1/4" FILLET WELDS

FABRICATOR	BASE METAL	ELECTRODE		
		E70	E90	E110
WEST COAST (W)	A-36	TW37A		
		TW37B		
		TW37C		
WEST COAST (W)	A-441	TW47A	TW49A	
		TW47B	TW49B	
		TW47C	TW49C	
WEST COAST (W)	A-514	TW57A	TW59A	TW51A
		TW57B	TW59B	TW51B
		TW57C	TW59C	TW51C
EAST COAST (E)	A-36	TE37A		
		TE37B		
		TE37C		
EAST COAST (E)	A-441	TE47A	TE49A	
		TE47B	TE49B	
		TE47C	TE49C	
EAST COAST (E)	A-514	TE57A	TE59A	TE51A
		TE57B	TE59B	TE51B
		TE57C	TE59C	TE51C

IDENTIFICATION NUMBER KEY

- 1ST DIGIT = (T) MEANS TRANSVERSE WELD TEST
- 2ND DIGIT = FABRICATOR IDENTIFICATION, E OR W
- 3RD DIGIT = BASE METAL IDENTIFICATION, 3 = A-36, 4 = A-441, 5 = A-514
- 4TH DIGIT - ELECTRODE IDENTIFICATION, 7 = E70, 9 = E90, 1 = E110
- 5TH DIGIT = SAMPLE NUMBER FOR EACH TYPE OF SPECIMEN

## DATA SHEET - TRANSVERSE FILLET WELDS

SPECIMEN NO.	GAUGE LENGTH	L 1	L 2	P	T	W	LOAD KIPS
TE37A	2.48	.27	.31	.21	.20	.24	126
	2.57	.29	.29	.21	.21	.25	
Average or Total	5.05	.28	.30	.21	.205	.245	
TE37B	2.51	.28	.34	.24	.22	.29	126
	2.58	.29	.29	.21	.21	.24	
Average or Total	5.09	.285	.315	.225	.215	.265	
TE37C	2.51	.27	.31	.21	.21	.28	124
	2.49	.28	.34	.24	.22	.28	
Average or Total	5.00	.275	.325	.225	.215	.28	
TE47A	2.55	.27	.33	.22	.21	.31	133
	2.55	.31	.30	.22	.21	.30	
Average or Total	5.10	.29	.315	.22	.21	.305	
TE47B	2.55	.32	.30	.22	.22	.28	136
	2.55	.31	.30	.24	.21	.30	
Average or Total	5.10	.315	.30	.23	.215	.29	
TE47C	2.54	.27	.31	.22	.21	.27	130
	2.57	.27	.24	.24	.18	.25	
Average or Total	5.11	.27	.275	.23	.195	.26	

NOTES: DIMENSIONS GIVEN ARE IN INCHES  
SEE DRAWING D-6 FOR LOCATION OF SYMBOLS L, P, T & W

## DATA SHEET - TRANSVERSE FILLET WELDS

SPECIMEN NO.	GAUGE LENGTH	L 1	L 2	P	T	W	LOAD KIPS
TE57A	2.62	.24	.31	.21	.19	.28	129.5
	2.62	.27	.29	.19	.20	.23	
Average or Total	5.24	.255	.30	.20	.195	.255	
TE57B	2.56	.27	.30	.21	.20	.28	131
	2.57	.24	.31	.21	.19	.24	
Average or Total	5.13	.255	.305	.21	.195	.26	
TE57C	2.45	.33	.30	.23	.22	.29	133
	2.46	.27	.30	.21	.20	.26	
Average or Total	4.91	.30	.30	.22	.21	.275	
TE49A	2.50	.28	.29	.22	.20	.28	136.5
	2.50	.31	.28	.22	.21	.29	
Average or Total	5.00	.295	.285	.22	.205	.285	
TE49B	2.53	.32	.29	.24	.22	.29	140.
	2.48	.31	.33	.24	.23	.30	
Average or Total	5.01	.315	.31	.24	.225	.295	
TE49C	2.53	.28	.29	.22	.20	.27	128
	2.52	.31	.28	.22	.21	.31	
Average or Total	5.05	.295	.285	.22	.205	.29	

NOTES: DIMENSIONS GIVEN ARE IN INCHES  
SEE DRAWING D-6 FOR LOCATION OF SYMBOLS L, P, T & W

## DATA SHEET - TRANSVERSE FILLET WELDS

SPECIMEN NO.	GAUGE LENGTH	L 1	L 2	P	T	W	LOAD KIPS
TE59A	2.55	.32	.31	.24	.22	.23	149
	2.59	.38	.30	.23	.24	.30	
Average or Total	5.14	.350	.305	.235	.23	.265	
TE59B	2.51	.32	.31	.24	.22	.29	143.5
	2.39	.30	.29	.25	.21	.29	
Average or Total	4.90	.31	.30	.245	.215	.29	
TE59C	2.47	.38	.30	.25	.24	.31	143
	2.47	.32	.31	.27	.22	.32	
Average or Total	4.94	.35	.305	.26	.23	.315	
TE51A	2.65	.27	.33	.20	.21	.24	184
	2.73	.32	.32	.24	.23	.31	
Average or Total	5.38	.295	.325	.22	.22	.275	
TE51B	2.52	.29	.33	.23	.22	.30	180
	2.51	.32	.32	.24	.23	.31	
Average or Total	5.03	.305	.325	.235	.225	.305	
TE51C	2.62	.32	.32	.23	.23	.31	177.5
	2.63	.24	.34	.21	.20	.29	
Average or Total	5.25	.28	.33	.22	.215	.30	

NOTES: DIMENSIONS GIVEN ARE IN INCHES  
SEE DRAWING D-6 FOR LOCATION OF SYMBOLS L, P, T & W

## DATA SHEET - TRANSVERSE FILLET WELDS

SPECIMEN NO.	GAUGE LENGTH	L <sub>1</sub>	L <sub>2</sub>	P	T	W	LOAD
TW37A	2.51	.27	.27	.20	.18	.21	108250
	2.51	.26	.30	.23	.20	.24	
Average or Total	5.02	.265	.285	.215	.19	.225	
TW37B	2.49	.28	.28	.20	.19	.24	108250
	2.50	.25	.29	.24	.18	.23	
Average or Total	4.99	.265	.285	.22	.185	.235	
TW37C	2.41	.24	.30	.24	.18	.22	103500
	2.42	.31	.21	.19	.18	.23	
Average or Total	4.83	.275	.255	.215	.18	.225	
TW47A	2.42	.23	.26	.21	.17	.22	115250
	2.43	.28	.28	.21	.21	.25	
Average or Total	4.85	.255	.27	.21	.19	.235	
TW47B	2.52	.25	.26	.19	.18	.25	128000
	2.54	.26	.28	.21	.19	.24	
Average or Total	5.06	.255	.27	.20	.185	.245	
TW47C	2.46	.27	.26	.22	.18	.25	119500
	2.47	.25	.28	.22	.18	.23	
Average or Total	4.93	.26	.27	.22	.18	.24	

NOTES: DIMENSIONS GIVEN ARE IN INCHES  
SEE DRAWING D-6 FOR LOCATION OF SYMBOLS L, P, T & W

## DATA SHEET -- TRANSVERSE FILLET WELDS

SPECIMEN NO.	GAUGE LENGTH	L 1	L 2	P	T	W	LOAD
TW57A	2.48	.28	.28	.23	.19	.23	112500
	2.49	.28	.29	.23	.20	.25	
Average or Total	4.97	.28	.285	.23	.195	.24	
TW57B	2.55	.28	.29	.21	.20	.25	119000
	2.58	.27	.26	.22	.19	.25	
Average or Total	5.13	.275	.275	.215	.195	.25	
TW57C	2.51	.28	.28	.22	.20	.29	102000
	2.51	.26	.27	.22	.19	.23	
Average or Total	5.02	.27	.275	.22	.195	.26	
TW49A	2.61	.29	.28	.21	.21	.22	109750
	2.63	.23	.27	.20	.18	.20	
Average or Total	5.24	.26	.275	.205	.195	.21	
TW49B	2.48	.25	.29	.21	.19	.23	102500
	2.48	.23	.27	.20	.18	.22	
Average or Total	4.96	.24	.28	.205	.185	.225	
TW49C	2.49	.22	.30	.21	.17	.22	95750
	2.49	.23	.27	.20	.18	.22	
Average or Total	4.98	.225	.285	.205	.175	.22	

NOTES: DIMENSIONS GIVEN ARE IN INCHES  
SEE DRAWING D-6 FOR LOCATION OF SYMBOLS L, P, T & W

## DATA SHEET - TRANSVERSE FILLET WELDS

SPECIMEN NO.	GAUGE LENGTH	L 1	L 2	P	T	W	LOAD
TW59A	2.48	.31	.27	.23	.20	.23	119500
	2.47	.26	.28	.19	.19	.21	
Average or Total	4.95	.285	.275	.21	.195	.22	
TW59B	2.55	.30	.27	.22	.20	.26	125750
	2.50	.25	.26	.21	.19	.26	
Average or Total	5.05	.275	.265	.215	.195	.26	
TW59C	2.51	.30	.28	.21	.21	.23	128500
	2.50	.24	.27	.21	.20	.24	
Average or Total	5.01	.27	.275	.21	.205	.235	
TW51A	2.45	.27	.24	.20	.18	.23	137500
	2.45	.26	.25	.21	.18	.24	
Average or Total	4.90	.265	.245	.205	.18	.235	
TW51B	2.47	.27	.250	.19	.18	.25	136000
	2.52	.28	.25	.21	.19	.25	
Average or Total	4.99	.275	.25	.20	.185	.25	
TW51C	2.48	.29	.27	.21	.21	.25	135000
	2.46	.30	.26	.22	.20	.22	
Average or Total	4.94	.295	.265	.215	.205	.235	

NOTES: DIMENSIONS GIVEN ARE IN INCHES  
SEE DRAWING D-6 FOR LOCATION OF SYMBOLS L, P, T & W

A 36 East Average 38.2 / 68.7  
 A441 " " 53.3 / 80.8  
 A514 " " 109.2 / 122.0

MECHANICAL TESTS

JOB A.W.S. Fillet Weld Study  
 SPECIMEN Base metal used for specimens

A.S.T.M. Desig.	HEAT NUMBER	SIZE	AREA SQ. IN.	LOAD IN POUNDS		LBS. PER SQ. IN.		ELONGATION		IN/8 IN.	NATURE OF FRACTURE	BEND TEST
				YIELD POINT	MAXIMUM LOAD	YIELD POINT	TENSILE STRENGTH	2 IN. IN.	PER CENT			
A36	PAA66C406	.505 x 1.511	.763	31750	55000	41610	72080	.92	46.0	2.31	Silky	----
A36	PAC72C700	.762 x 1.527	1.164	43250	76500	37160	62720	1.18	59.0	2.45	Silky	----
A36	PAH70C711	1.017 x 1.506	1.532	56750	105250	37040	68700	.67	33.5	2.34	Silky	----
A36	PAN40-450	1.258 x 1.511	1.901	70250	137250	36950	72200	1.08	54.0	2.00	Silky	----
A-441	PRA69C471	.493 x 1.509	.744	37500	55750	50400	74930	.93	46.5	1.99	Silky	----
A-441	PBC74B131	.749 x 1.568	1.174	65000	96500	55370	82200	.97	48.5	1.95	Silky	----
A-441	PEH71B264	1.000 x 1.509	1.509	88000	129500	58320	85820	1.07	53.5	1.94	Silky	----
A-441	PBM65B677	1.259 x 1.628	2.050	100500	164750	49020	80370	1.15	57.5	2.12	Silky	----
A-514	PCA73B886	.506 x 1.551	.785	86000	93250	109550	118790	.62	31.0	1.13	Silky	----
A-514	PCC66B008	.768 x 1.391	1.068	107000	117500	100190	11020*	.69	34.5	1.12	Silky	----
A-514	(Retest) PCC66B008	.767 x 1.627	1.248	136250	148250	109170	118790	.75	37.5	1.10	Silky	----
A-514	PCH71C675	1.016 x 1.433	1.456	165750	179500	113840	123280	.72	36.0	1.23	Silky	----

REMARKS: East Coast base metal. \* Failure, see retest following.  
 REPORTED TO:

BY R.A. Kuntz



MECHANICAL TESTS

JOB A.W.S. Fillet Weld Study  
 SPECIMEN Base metal used for specimens

HEAT NUMBER	SIZE	AREA SQ. IN.	LOAD IN POUNDS		LBS. PER SQ. IN.		ELONGATION		IN/8 IN.	NATURE OF FRACTURE	BEND TEST
			YIELD POINT	MAXIMUM LOAD	YIELD POINT	TENSILE STRENGTH	IN	PER CENT			
A-514	1.279 x 1.454	1.860	194000	236250	104300	127020	.73	36.5	1.07	Silky	---

REMARKS: East Coast Base Metal  
 REPORTED TO:

BY R.A. Kuster

A36 West Average 32.3 / 67.3 Overall Average 38.8 / 67.7  
 A441 " " 50.8 / 79.2 (E + W) 50.8 / 79.2  
 A514 " " 111.5 / 120.2 110.5 / 121

MECHANICAL TESTS

JOB A.I.S.C. Fillet Weld Test  
 SPECIMEN Base metal used for specimens

A.S.T.M. Desig.	HEAT NUMBER	SIZE	AREA SQ. IN.	LOAD IN POUNDS		LBS. PER SQ. IN.		ELONGATION		IN/8 IN.	NATURE OF FRACTURE	BEND TEST
				YIELD POINT	MAXIMUM LOAD	YIELD POINT	TENSILE STRENGTH	2 IN IN.	PER CENT			
A-36	8129117	.767 x 1.517	1.164	40500	74500	34790*	64000	1.19	59.5	2.67	Silky	---
A-36	8129117	.794 x 1.513	1.201	42500	74250	35390**	61820	.67	33.5	2.68	Silky	---
A-36	8247653	1.020 x 1.475	1.505	52750	100500	35050*	66780	1.21	60.5	2.66	Silky	---
A-36	8247653	1.018 x 1.513	1.540	61250	104500	39770**	67860	.66	33.0	2.64	Silky	---
A-36	9906672	1.271 x 1.433	1.821	69250	136500	47370	74960	1.20	60.0	2.40	Silky	---
A-36	328859	1.490 x .764	1.138	49100	77500	43150	68100	1.06	53.0	2.30	Silky	---
A-441	72215	.502 x 1.554	.780	39900	61600	51150	78970	1.00	50.0	2.17	Silky	---
A-441	24258	.754 x 1.533	1.156	59000	89750	51040	77640	1.01	50.5	2.09	Silky	---
A-441	24258	.774 1.495	1.157	58300	90000	50390	77790	1.00	50.0	2.16	Silky	---
A-441	96A337	1.030 x 1.453	1.497	72000	117750	48100	78660	1.03	51.5	2.05	Silky	---
A-441	97B216	1.288 x 1.534	1.976	105750	164250	53520	83120	.98	49.0	1.98	Silky	---
A-514	66C281	.520 x 1.498	.779	78250	84500	100450	108470*	.63	31.5	1.07	Silky	---

REMARKS: West Coast base metal.

REPORTED TO:

BY R. H. Kloster

**MECHANICAL TESTS**

JOB SPECIMEN **A.I.S.C. Fillet Weld Test**  
**Base metal used for specimens**

A.S.T.M. Desig.	HEAT NUMBER	SIZE	AREA SQ. IN.	LOAD IN POUNDS		LBS. PER SQ. IN.		ELONGATION		IN/8 IN.	NATURE OF FRACTURE	BEND TEST
				YIELD POINT	MAXIMUM LOAD	YIELD POINT	TENSILE STRENGTH	IN 2 IN.	PER CENT			
A-514	81P337	.780 x 1.544	1.204	131500	141250	109220	117320	.60	30.0	1.00	Silky	---
A-514	73B665	.743 x 1.535	1.141	131000	141250	114810	123790	.64	32.0	1.01	Silky	---
A-514	60B044	1.019 x 1.435	1.462	157000	171000	107390	116960	.69	34.5	1.03	Silky	---
A-514	99P795	1.263 x 1.493	1.886	233250	250000	123670	132560	.61	30.5	.96	Silky	---
A-514	66C281	.518 x 1.513	.784	80200	86600	102300	110450**	.65	32.5	1.15	Silky	---

REMARKS: West \* Failure  
 REPORTED TO: \*\* Retest

BY R. A. Kenner

