

STUDENT STEEL BRIDGE COMPETITION

2008 RULES

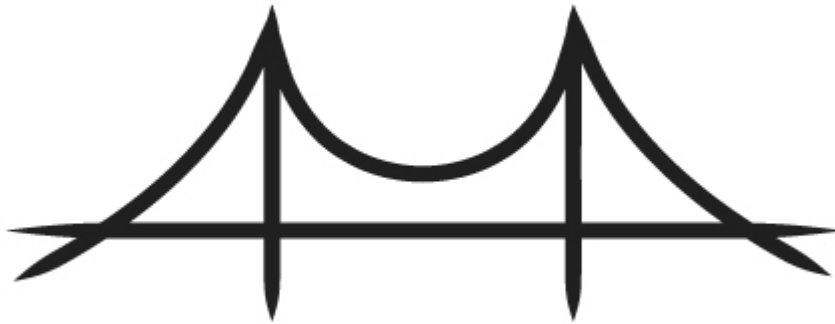

The mission of the ASCE/AISC Student Steel Bridge Competition (SSBC) is to supplement the education of civil engineering students with a comprehensive, student-driven project experience from conception and design through fabrication, erection and testing, culminating in a steel structure that meets client specifications and optimizes performance and economy. The SSBC increases awareness of real-world issues such as spatial constraints, material properties, strength, serviceability, fabrication and erection processes, safety, esthetics and cost. Success in inter-collegiate competition requires effective team work and project management. Future engineers are stimulated to innovate, practice professionalism and use structural steel efficiently.

TABLE OF CONTENTS

	<u>page</u>
1. Introduction	3
2. Executive Summary	4
3. Eligibility	5
4. Rule Changes	6
5. Safety	6
6. Problem Statement	7
7. Scoring	8
8. Schedule of Competition	10
9. Dimensions and Support	11
10. Material and Components	14
11. Construction	17
12. Load Tests	25
13. Equipment Provided by Host	30
14. Interpretation of Rules	32
15. Judging	32
16. Appeals	33
17. Summary of Scoring	35
APPENDIX	
Site and Bridge Diagram	37
Bridge Loading Diagram	38

Any revisions to the rules in this document are incorporated in clarifications that are published at the bridge competition web site, <http://www.aisc.org/steelbridge.html>. Revisions and clarifications do not appear in this document but are considered formal addenda to the *Rules*.

1. INTRODUCTION

The Student Steel Bridge Competition is sponsored by the American Society of Civil Engineers (ASCE) and by the American Institute of Steel Construction (AISC), and co-sponsored by the American Iron and Steel Institute, the James F. Lincoln Arc Welding Foundation, the National Steel Bridge Alliance, and the Nucor Corporation.

Students design a steel bridge by themselves but may seek advice from faculty and student organization advisers. Students gain maximum benefit from the experience if they design and fabricate the entire bridge themselves. However, because appropriate shop facilities and supervision are not available at all universities, students may use the services of a commercial fabricator provided that they develop the work orders and observe the operations. Students are encouraged to maximize their involvement in fabrication.

Safety is of primary importance. AISC and ASCE request that competitors, advisers, hosts, and judges take all necessary precautions to prevent injury.

This document describes the competition and states the rules for this year. It is available at <http://www.aisc.org/steelbridge.html>, together with related information. These rules govern competition at both regional and national levels. Additional information is available at <http://www.nssbc.info>. Information and rules at <http://www.aisc.org/steelbridge.html> will govern if there is a conflict between the two sites.

The rules are changed every year to improve the competition and assure that competitors design and build new bridges. The rules are intended to be prescriptive but may require some interpretation. The procedure for requesting clarification of the rules is described in chapter "14 Interpretation of Rules." Revisions to the rules, if any, will be incorporated in the clarifications that appear on the web page cited in that chapter.

2. EXECUTIVE SUMMARY

Civil Engineering students are challenged to an inter-collegiate competition that includes design, fabrication, and construction of a scaled steel bridge. Participating students gain practical experience in structural design, fabrication processes, construction planning, organization, and teamwork.

The rules of the competition simulate a request for proposal that requires a scaled model to demonstrate the efficacy of competing designs. Chapter “6 Problem Statement” relates the rules to realistic challenges encountered in bridge design and construction.

Standards for strength, durability, constructability, usability, functionality, and safety reflect the volumes of regulations that govern the design and construction of full-scale bridges. Criteria for excellence are represented by the award categories of stiffness, lightness, construction speed, display, efficiency and economy. Competition judges and the Rules Committee take the role of the owner (Department of Transportation) and have the authority to accept and reject entries.

The safety of competitors, judges, and spectators is paramount. Risky procedures are prohibited, and bridges that cannot be constructed and tested safely are withdrawn from competition. In addition, the rules identify and penalize construction errors that represent accidents in full-scale construction.

The rules of the competition accommodate a variety of designs and allow innovation. Designers must consider carefully the comparative advantages of various alternatives. For example, a truss bridge may be stiffer than a girder bridge but slower to construct. Successful teams analyze and compare alternative designs prior to fabrication.

The Student Steel Bridge Competition provides design and construction planning experience, an opportunity to learn fabrication procedures, and the excitement of competing against and networking with students from other colleges and universities.

3. ELIGIBILITY

3.1. Regional Competition

There are two levels of competition: regional and national. Regional competitions are held in conjunction with ASCE student conferences. Only one bridge per college or university may compete in an ASCE student conference, and a college or university may compete in only one ASCE student conference.

The ASCE student organizations entering regional competitions are required to be current with their national dues and annual reports. A team must consist only of undergraduate and graduate students in good standing with their ASCE student organization.

A student team which does not have an ASCE student organization that meets the requirements of the preceding paragraph may enter a steel bridge in a regional competition if invited by the conference host organization. Such teams are invited guests and will not be ranked in the competitions nor will they be invited to compete in the National Student Steel Bridge Competition.

An ASCE student organization will not be permitted to participate in the National Student Steel Bridge Competition unless it satisfies ASCE regulations regarding participation in its ASCE student conference. These regulations are stated at www.asce.org/students.

3.2. National Competition

Invitations to compete at the national level are extended only to the winner from an ASCE student conference in which two, three, or four ASCE student organizations participated in the Student Steel Bridge Competition, to the top two teams from a conference in which five to ten ASCE student organizations competed, and to the top three teams from a conference with eleven or more competing ASCE student organizations. Guest teams will not be invited to the national competition and will not be counted when determining how many teams will be invited from a conference. Only one bridge per college or university may be entered in the national competition.

4. RULE CHANGES

The following list covers some of the major changes from the 2007 rules. Not all changes are listed. Contestants, hosts, and judges are cautioned to **read this entire document carefully and disregard rules and clarifications from previous years.**

1. Scoring multipliers are different.
2. University name on the bridge and poster must match the name registered with ASCE.
3. Poster must give credit to consultants, technicians, and fabricators who helped.
4. Width of river and span of bridge are increased.
5. Clearance under the bridge is increased.
6. Height of the bridge is decreased.
7. Threads of nuts must be fully engaged.
8. One or two builders may be designated as “barges” and will operate in the river but not on land.
9. Touching the floodway on either side of the river is penalized as an accident.
10. “Superintendent” designation is eliminated. A builder or builders may supervise from inside the construction site while also constructing.
11. Builders must demonstrate stability of the constructed portion.

5. SAFETY

Safety has the highest priority. Judges are empowered to halt any activity that they deem hazardous. Judges will stop construction procedures that could cause personal injury. Judges will not allow additional load to be placed on a bridge that has collapsed, that is approaching a collapse that could be dangerous, or that has swayed or deflected in excess of specified limits. A bridge that cannot be safely constructed or load tested using the equipment provided by the host is not eligible for awards in any category and must be withdrawn from participation.

6. PROBLEM STATEMENT

A century-old bridge that spans a river and adjacent floodways must be replaced. The bridge carries traffic serving the residences, farms, and agricultural processing industries that are the economic base of this rural region. A quick replacement is necessary because no other crossing is available for miles.

The state Department of Transportation (DOT) has requested design/build proposals for replacing the existing bridge. Any appropriate type of bridge will be considered but the DOT has specified steel as the material because of its durability, fast erection, and high level of recycled content. Clearance under the bridge must be provided for passage of floods. The bridge must be able to carry specified patterns of loads without exceeding sway and deflection limits. Based on past experience with performance and maintenance, the DOT prefers bridges that are relatively light and stiff. The new bridge must accommodate modular decking that was salvaged from another structure.

Due to environmental concerns, construction of permanent piers is permitted only on the existing footings. However, temporary piers may be used. Construction barges are permitted in the river. Both sides of the river are bounded by floodways that are too shallow for barges and too wet for terrestrial construction machinery. Soil conditions limit the weight of loads that may be moved. Existing revetments protect steep slopes and must not be damaged by construction equipment.

Your company's design/build proposal is among those that the DOT has deemed responsive, and winning the contract would be a step toward becoming a leader in the bridge replacement market. The DOT has asked each competing firm to submit a 1:10 scale model to demonstrate its concept. Models will be erected under simulated field conditions and then load tested. A panel of DOT personnel will judge the models by multiple criteria including durability, constructability, usability, stiffness, construction speed, efficiency, economy, and display. The contract will be awarded to the company whose model best meets the DOT's needs and requirements. Any attempt to gain advantage by circumventing the intent of the competition as expressed by the rules, including this Problem Statement, will be grounds for rejection of the model and termination of the company's eligibility.

7. SCORING

A college or university may enter only one bridge in regional competition and may participate in only one regional competition.

Categories of competition are display, construction speed, lightness, stiffness, construction economy, and structural efficiency. In addition, overall performance is rated. A bridge that was not approved for load testing or that failed in load testing is not eligible for awards in any category.

7.1. Display

Display is the tie-breaker for all categories of competition. Judges should not declare ties in display. Display is judged by

7.1.1. Appearance of bridge, including balance, proportion, elegance, and finish. Quality of fabrication should not be considered because some bridges may be fabricated professionally while others are student work.

7.1.2. Permanent identification of the bridge consisting of the name of the college or university exactly as shown on the ASCE register available at www.asce.org/students. The name must appear on the bridge in letters at least one inch high and must be formed from steel or applied to steel with paint or decals. A 50-pound weight penalty will be imposed if the bridge lacks appropriate identification.

7.1.3. Poster describing design. The poster must be flat with maximum dimensions of two by three feet and must present all information on one side without attached pages that must be lifted or turned. The poster must identify the college or university with the same name that appears on the bridge and must present a brief explanation of why the overall configuration of the bridge was selected, a brief computation demonstrating design for one limit state, a scaled, dimensioned side view of the bridge, and acknowledgment of companies, university technicians, faculty, and others who helped fabricate the bridge or provided advice. Additional information may be included. Electronic displays, decorated supports, lights, and sound are not permitted and will result in the worst possible rating for the poster. A fifty-pound weight penalty will be imposed if there is no poster or if it is grossly inadequate. The poster is not part of the bridge but must be in place whenever the bridge is on display.

7.2. Construction Speed

The bridge with the lowest total time will win in this category. Total time is the time required for construction plus 150% of the time for repairs (see section 11.9), modified by penalties prescribed in sections 11.6, 11.7, 11.9, 12.2, 12.4, and 12.5. There is an upper limit on construction time.

7.3. Construction Economy

The bridge with the lowest construction cost (C_c) will win in the construction economy category. Construction cost (thousand \$) is computed as

$$C_c = \text{Total time (minutes)} \times \text{Number of builders (including barges)} \\ \times 50 \text{ thousand dollars per person-minute} \\ + 20 \text{ thousand dollars for every move of a temporary pier} \\ + 30 \text{ thousand dollars for each barge.}$$

Total time is defined in section “7.2 Scoring: Construction Speed” and includes penalties. The number of builders includes all members and associates of the competing organization who are within the construction site or physically assist the team at any time during timed construction.

7.4. Lightness

The bridge with the least total weight will win in the lightness category. Total weight is the weight of the bridge plus weight penalties prescribed in sections “7.1 Scoring: Display,” “9.2 and 9.3 Dimensions and Support: Usability and Centerline,” “10.2 Material and Components: Durability and Constructability” and “12.4 and 12.5 Load Tests: Lateral Load Test and Vertical Load Test.” Decking, tools, temporary piers, and poster are not included in total weight.

7.5. Stiffness

The bridge with the lowest aggregate deflection will win in the stiffness category. Aggregate deflection is determined from measurements as prescribed in section “12.5 Load Tests: Vertical Load Test.”

7.6. Structural Efficiency

The bridge with the lowest structural cost will win in the structural efficiency category. Structural cost (thousand \$) is computed as

$$C_s = \text{Total weight (pounds)} \times 3 \text{ thousand dollars per pound} \\ + \text{Aggregate deflection (inches)} \times 700 \text{ thousand dollars per inch.}$$

Total weight is defined in section “7.4 Scoring: Lightness” and includes penalties. Aggregate deflection is defined in section “7.5 Scoring: Stiffness” and includes penalties.

7.7. Overall Performance

The overall performance rating of a bridge is the sum of construction cost and structural cost ($C_c + C_s$). The bridge achieving the lowest value of this total wins the overall competition.

8. SCHEDULE OF COMPETITION

In the months before the competition, students design their bridges, fabricate members, test load, practice construction, and select a member of the team to serve as its captain. The following events occur during the competition

1. Bridges are erected for public viewing and are judged for display. After the start of display judging, bridges must not be altered, modified, or enhanced in any way except for disassembly, erection, and repairs as described in section “11.9 Construction: Repairs.”
2. Bridges are disassembled.
3. The head judge clarifies rules and conditions of the competition and answers questions.
4. The head judge selects the locations of loads. See section “12.5 Load Tests: Vertical Load Test” and the “Locations of Targets and Decking” detail on the “Bridge Loading” diagram. Selection is done in the presence of the team captains by rolling a die twice. Let S1 and S2 be the spots from the two rolls and let L1 and L2 be dimensional locations of decking units in inches.
$$L1 = 40 + 7 (S1) \quad \text{and} \quad L2 = 115 + 7 (S2)$$

The same locations will be used for all bridges.
5. Bridge members, fasteners, tools, and temporary piers are staged for construction and inspected by the judges. See chapter “10 Material and Components” for details.
6. Timed construction. See chapter “11 Construction” for details.
7. Judges inspect assembled bridges. See chapter “9 Dimensions and Support” and rules 10.1.2, 10.1.3, 10.2.11, 10.2.12, and 10.2.13 for details.
8. Bridges are weighed (if it is impractical to weigh the entire bridge, its parts may be weighed prior to construction).
9. Load testing. See chapter “12 Load Tests” for details.
10. The host ASCE student organization must submit the completed official scoring spread sheet by e-mailing it to the address given on that spread sheet, which is aftbq@uaa.alaska.edu.

The order recommended above may be altered. However, it is essential that

- bridges are not modified after selection of load locations,
- bridges are not modified between display judging and timed construction,
- no components or tools are added to or removed from the construction site after staging and inspection, and
- modifications between timed construction and load testing are limited to repairs as described in “11.9 Construction: Repairs.”

9. DIMENSIONS AND SUPPORT

Dimensions and support will be checked with the bridge in its as-built condition after construction is completed and before the bridge is moved from the construction site or load tested. The bridge must not be modified or distorted from its as-built condition in order to satisfy dimension and support rules. Dimensions will be checked without decking or any applied load on the bridge.

9.1. Functionality and Safety

If any of the following rules in this section (9.1) is violated, the bridge will not be approved for load testing and will not be eligible for awards in any category.

9.1.1. The bridge must span the river and floodways without touching them. See the "Site Plan" on the "Site and Bridge" diagram.

9.1.2. The bridge must provide support for the decking for the full overall length of the bridge along both of the edges that run in the span direction of the bridge. See the "Elevation" on the "Site and Bridge" diagram.

9.1.3. Decking support must be rigid. At their discretion, judges may test rigidity by applying a 25-pound load at selected points on the decking support. Deflection under that load exceeding one inch indicates lack of rigidity.

9.1.4. The bridge must provide access for placing the decking and load.

9.1.5. The decking must not be attached or anchored to the bridge, and it must not be used to distort the bridge from its as-built condition.

9.1.6. The bridge must not be anchored or tied to the ground.

9.1.7. It must be possible to construct and load the bridge safely using equipment provided by the host student organization. **Bridges must accommodate local conditions.**

9.2. Usability

A weight penalty will be assessed for each rule in this section (9.2) that is violated, rather than for every violation of that rule.

The penalty for violation of each of the following rules will be an addition to the weight of the bridge determined as follows: 50 pounds for a dimensional violation of $\frac{1}{2}$ inch or less; 150 pounds for a dimensional violation greater than $\frac{1}{2}$ inch but not exceeding 1.0 inch; 300 pounds for a dimensional violation greater than 1.0 inch but not exceeding 2.0 inches. If a dimensional violation exceeds 2.0 inches, the bridge will not be approved for load testing and will not be eligible for awards in any category.

9.2.1. The bridge must bear on the ground only within the one-foot by one-foot squares that are marked on the construction site to represent existing footings. See the “Site Plan” on the “Site and Bridge” diagram.

9.2.2. Decking support surfaces must not be more than 21’0” long and must extend for the overall length of the bridge.

9.2.3. Parts of the bridge (including fasteners and parts that bear on the ground) must not extend beyond the vertical plane defined by the ends of the decking support surfaces at each end of the bridge.

9.2.4. The bridge must be able to accommodate solid decking that is $3\frac{1}{2}$ inches thick and extends $1'10\frac{1}{2}"$ on both sides of the nominal centerline (described in section 9.3) at all points along the length of the bridge. This rule will be checked along the full overall end-to-end length of the decking support surfaces using a 3’9” wide template centered on the nominal centerline.

9.2.5. The lateral distance from the nominal centerline to the outer edge of the outermost decking support surface on each side of the bridge must not be less than 1’3”. See the “Decking Support” detail on the “Site and Bridge” diagram.

9.2.6. The lateral distance from the nominal centerline to the inner edge of the outermost decking support surface on each side of the bridge must not be more than $1'6\frac{1}{2}"$. See the “Decking Support” detail on the “Site and Bridge” diagram.

9.2.7. The decking support surfaces must not have gaps exceeding $\frac{1}{4}$ inch wide in the span direction of the bridge. See the “Irregularities in Decking Support” detail on the “Site and Bridge” diagram.

9.2.8. The decking support surfaces must not have vertical protrusions exceeding $\frac{1}{4}$ inch high. See the “Irregularities in Decking Support” detail on the “Site and Bridge” diagram.

9.2.9. Elevation of the decking support surface must not change more than $\frac{1}{4}$ inch in any six inches of span length. See the “Irregularities in Decking Support” detail on the “Site and Bridge” diagram.

9.2.10. The decking support surface must be no less than 2’3” nor more than 2’6” above the surface of the ground or river at any point. See the “Elevation” on the “Site and Bridge” diagram.

9.2.11. The bridge must not extend more than 6’0” above the surface of the ground or river. See the “Elevation” on the “Site and Bridge” diagram.

9.2.12. Clearance must be provided under the bridge at all points directly over the river and floodways. The clearance must be at least 2’1” high, measured from the surface of the river and floodway. See the “Elevation” on the “Site and Bridge” diagram.

9.2.13. At all other points that are not directly over the river, floodways, or footings, there must be clearance of at least 6” under the bridge. See the “End View” on the “Site and Bridge” diagram.

9.2.14. A vehicle passageway must completely traverse the bridge from end to end. It must be at least 2’0” high, measured from the decking support surfaces, and must extend at least 1’6” on each side of the nominal centerline. See the “End View” on the “Site and Bridge” diagram.

9.3. Nominal Centerline

A weight penalty of 100 pounds will be assessed if any of the requirements in this section (9.3) is violated or if some feature of the bridge prevents the judge from stretching a string along a designated straight nominal centerline.

9.3.1. The bridge must have a designated straight nominal centerline extending from one end to the other. The centerline must be designated by two holes, one at each end of the bridge, drilled vertically through horizontal steel surfaces at the level of the decking support surfaces. Each hole must be approximately $\frac{1}{4}$ inch in diameter and must be located no more than 3’0” from the vertical plane defined by the ends of the decking support surfaces.

10. MATERIAL AND COMPONENTS

10.1. Safety

If any one of the following rules in this section (10.1) is violated, the bridge will not be approved for construction or load testing, and will not be eligible for awards in any category.

10.1.1. A member must not weigh more than twenty pounds. See section 10.2 for definition of “member.”

10.1.2. A bridge must not incorporate an electric, electronic, fluidic, or other non-mechanical sensor or control system; a non-mechanical energy transmission device such as a wire, duct, or tube; an energy conversion or storage device such as an electromagnet, electric cell, motor, hydraulic or pneumatic piston, turbine, chemical reactor, pressure vessel, pre-loaded spring, or triggering device.

10.1.3. After completion of timed construction, energy must not be transmitted to or from a bridge (for example, by applying or releasing mechanical, magnetic, fluidic, or other force; by sound, light, radio, or other wave or ray; by conduction or convection of heat; or by electric current). The exceptions are forces necessary to the competition (for example, those associated with load testing and with moving the bridge from place to place), and changes in ambient conditions that are not controlled by contestants (such as wind, temperature, and lighting).

10.2. Durability and Constructability

Violation of the following rules in this section (10.2) will result in penalties being added to the weight of the bridge. The penalty for each violation is ten pounds plus five times the weight of the non-conforming member or fastener. If the non-conforming component weighs less than one pound, its weight will be assumed to be one pound for the purpose of computing the penalty.

10.2.1. A bridge must be constructed only of structural steel. For the purposes of this competition, structural steel is defined as an iron alloy that is strongly attracted to any magnet provided by the host organization. Solder, brazing, and structural adhesives are not permitted. Exceptions: Paint, decals, and other purely decorative items are permitted, and bridge parts may be labeled.

10.2.2. A bridge must be constructed only of members and fasteners. During timed construction, members are connected with fasteners to form assemblies and the constructed portion, which are defined and regulated by rules in chapter “11 Construction.”

Members

10.2.3. A member is a rigid steel component that retains its shape and dimensions during timed construction and in the completed bridge.

10.2.4. A member must not exceed overall dimensions of 3'6" x 6" x 6." That is, it must fit in a prismatic box of those dimensions.

10.2.5. A member must retain its shape, dimensions, and rigidity during timed construction and load testing. Hinged, jointed, articulated, and telescoping members are prohibited, as are those with parts that move. This prohibition includes members with parts that are intended to slide, rotate, deflect, or bend relative to the member such as cams, latches, sliding pins, springs, and snap-lock devices. Also prohibited are members incorporating hinges or other devices that do not restrain rigid-body rotation or translation of one part of the member relative to another. Exception: Deformations caused by mechanical strain (e.g., bending, stretching) during load testing are not violations of this rule.

10.2.6. A member may consist of multiple parts rigidly joined together before timed construction begins. Those parts must remain rigidly joined throughout timed construction and in the completed bridge. Parts must be joined by welding or with steel connectors such as bolts, screws, and rivets. If nuts are used their threads must be fully engaged (that is, the end of the bolt or threaded pin must be flush with or extend beyond the outer face of the nut).

Fasteners

10.2.7. A fastener is a steel bolt that is not part of a member, with at least one steel nut that is not part of a member. The specified bolts and nuts usually are available in hardware stores.

10.2.8. The bolt in a fastener must be no more than three-inch nominal length (bottom of head to end) with a hexagonal head, and it must have the configuration and dimensions of a “cap screw grade 2,” “cap screw grades 5 and 8,” “A307 bolt,” “A325 and A490 structural bolt”, or “hex tap bolt” illustrated on <http://www.purchasepartners.com/fastenerspecs.htm>. Bolts must not be mechanically altered or modified in any manner. They may be painted.

10.2.9. The nuts in a fastener must match the bolt. That is, the nominal size (inside diameter) must be the same as that of the bolt and the threads of the nuts must engage the threads on the bolt and permit the nuts to be turned onto the bolt. Nuts must be solid, hexagonal, and have the configuration and dimensions of “finished hex nut grade 2,” “finished hex nut grades 5 and 8,” or “heavy hex nut” as illustrated on the web site cited in rule 10.2.8. Nuts must not be mechanically altered or modified in any manner. They may be painted.

10.2.10. Nuts and bolts that connect the parts of a member but do not connect a member to other members are not considered to be fasteners and are not governed by rules 10.2.7, 10.2.8, and 10.2.9.

Member-to-member Connections

10.2.11. Each member must be connected directly to every member that it touches by at least one fastener installed during timed construction so that the connection cannot be taken apart without first turning and removing a nut from the bolt.

10.2.12. The bolt must penetrate completely through a hole in each of the members that it connects. Dimension(s) of the hole must be small enough so that neither the head of the bolt specified in rule 10.2.8 nor the nut specified in rule 10.2.9 can pass through the hole.

10.2.13 The bolt must fully engage the threads of its nuts. That is, the end of the bolt must extend beyond, or be flush with, the outer surface of the outermost nut.

11. CONSTRUCTION

11.1. Definitions

11.1.1. “River,” “floodway,” “staging yard,” “footing,” and construction “site boundary” are defined by the “Site and Bridge” diagram. “Ground” is the entire floor, both inside and outside the site boundary, except for the river.

11.1.2. “Builders” are undergraduate or graduate student members of a competing student organization. See chapter 3 for eligibility requirements.

11.1.3. Some builders may be designated to be “barges.” Builders cannot be designated as barges after the start of timed construction and builders so designated remain barges for the duration of timed construction. The use of barges is optional. Barges are counted as builders and, in addition, the construction cost, C_c , is incremented for each barge that is used.

11.1.4. A “team” is all the builders from the organization that is constructing the bridge. The team must include no more than six builders. No more than two of those builders may be designated as barges.

11.1.5. “Personal protective equipment” consists of a hardhat meeting ANSI standard Z89.1 and protective eyewear or safety goggles meeting ANSI standard Z87.1. A team provides its own personal protective equipment.

11.1.6. A “tool” is a device that is used to construct the bridge and is not part of the completed bridge. A team provides its own tools.

11.1.7. “Temporary piers” are optional devices that bear on the river or ground, including floodways, and are used to support the constructed portion of the bridge during timed construction. They have no other purpose, are not tools, and are not part of the completed bridge. A team provides its own temporary piers. The construction cost, C_c , is incremented for every time a temporary pier is moved, including moves from and to a staging yard. However, there is no cost for moving a temporary pier from one location in a staging yard to another location in the same staging yard.

11.1.8. “Moving a temporary pier” means changing the orientation or horizontal position of its bearing surfaces on the ground or river. A move is considered complete when the temporary pier is released by the builder or builders who were moving it.

11.1.9. “Member,” “fastener,” and “member-to-member connection” are defined in section 10.2.

11.1.10. To “connect” means to attach with a member-to-member connection except that bolts are not required to completely penetrate nuts until construction and repairs are completed.

11.1.11. An “assembly” consists of members that are connected together in a staging yard during timed construction.

11.1.12. The “constructed portion” is created during timed construction by connecting members and assemblies in essentially their final positions. The constructed portion is not required to be contiguous.

11.1.13. When a member or assembly is connected to the constructed portion by at least one fastener it becomes part of the constructed portion and is no longer considered to be a member or assembly.

11.1.14. The constructed portion or a non-contiguous part of the constructed portion is “stable” if, without being supported by builders or by tools held by builders, it stands without falling and does not touch the river or the ground outside the footings. Temporary piers and tools that are not held by builders may be used to achieve the stable condition.

11.1.15. To “modify” includes, but is not limited to, making and taking apart connections, and installing, tightening, loosening and removing nuts and bolts.

11.2. Safety

If any rule in this section (11.2) is violated during timed construction, the judge will stop the clock and explain the violation. Before the clock is restarted, builders, tools, members, assemblies, fasteners, and temporary piers will be returned to the positions they occupied before the violation. Then the team will be asked to resume construction using safe procedures. A team will have the opportunity to construct its bridge safely. However, if the team is not able to construct its bridge completely using safe procedures, construction will cease and the bridge will not be approved for load testing and will not be eligible for awards in any category.

11.2.1. Builders, judges, and spectators must not be exposed to risk of personal injury.

11.2.2. Only builders and judges are permitted within the boundaries of the construction site during timed construction.

11.2.3. At all times during timed construction every builder must wear personal protective equipment in the proper manner (e.g., hardhat with peak in front).

- 11.2.4. Welding machines and tools requiring external power connections must not be used during timed construction.
- 11.2.5. A tool must not weigh more than twenty pounds and must not exceed 3'6" in any linear dimension when fully assembled and extended.
- 11.2.6. Tools, members, and assemblies may be supported on the constructed portion or on temporary piers. Rules 11.7.3 and 11.7.4 apply.
- 11.2.7. A temporary pier must not be moved while it is supporting the constructed portion, a member, an assembly, or a tool.
- 11.2.8. A temporary pier must not weigh more than twenty pounds and must not exceed 1'6" in any horizontal dimension.
- 11.2.9. A temporary pier must not collapse or fall over while in use.
- 11.2.10. A temporary pier must bear on the ground or river and not be supported or stabilized by builders or tools while it is supporting the constructed portion, a member, an assembly, or a tool.
- 11.2.11. Lubricant must not be applied during timed construction or within the construction site at any time. Lubricant must not drop on the floor within the construction site.
- 11.2.12. Throwing anything is prohibited.
- 11.2.13. A builder must not use the bridge, a portion of the bridge, a temporary pier, or a tool to support the builder's body weight. For example, lying, standing, sitting, or kneeling on those objects is prohibited. However, a builder may lean on a constructed portion if the builder is kneeling on the ground on both knees, kneeling on the ground on one knee with the other foot on the ground, or standing with the heels and toes of both feet on the ground.
- 11.2.14. A builder must not depend on another builder or builders for support or balance.
- 11.2.15. A builder must not cross a floodway or the river.
- 11.2.16. An assembly must not consist of more than three members.
- 11.2.17. Modification of a member or assembly is not permitted outside the staging yard. Furthermore, outside the staging yard, a member or assembly must not contact another member or assembly.

11.2.18. The bridge must be constructed by first placing members or assemblies in their final positions. These become the initial constructed portion. Then additional members and assemblies are successively connected to the constructed portion and become part of it. Outside the staging yard, connections must be made only to the constructed portion.

11.2.19. Surfaces of the constructed portion that bear on the ground must be the same surfaces that will bear on the ground in the completed bridge.

11.2.20. A constructed portion must be created in, and remain in, essentially the same location, position, and configuration that it will have in the completed bridge. Exceptions

- A former member or assembly that is connected to the constructed portion by only one fastener may rotate relative to the constructed portion.
- Due to lack of support from members that have not yet been connected to the constructed portion, part of it may sag or sway.
- The constructed portion may slide from its final position on the ground as an unintended consequence of construction. However, intentional movement of the constructed portion from its final position is a violation.

For all three exceptions, one or more builders may move all or part of the constructed portion in order to make a connection or correct the position of the bridge on the footings. However, rule 11.7.3 applies.

11.2.21. A constructed portion may be modified as described by 11.1.15.

11.2.22. The constructed portion and every non-contiguous part of the constructed portion must be stable. After each member or assembly is connected to the constructed portion, the builders must demonstrate stability by releasing the constructed portion, including the newly-connected member or assembly and all members and assemblies that are in contact with the constructed portion, and then announcing “stable” loud enough for the judges to hear.

11.2.23. Outside the staging yard, moving or supporting an assembly requires the effort of at least two builders. “Moving” includes, but is not limited to lifting, carrying, lowering, rolling, turning, sliding, tipping, and rotating.

11.2.24. Outside the staging yard, a builder must not contribute to lifting, carrying, or supporting more than one member or assembly at a time.

11.2.25. A builder must not move or support a temporary pier while also moving or supporting a member, assembly, or another temporary pier.

11.2.26. A builder may support a member, assembly, or temporary pier while simultaneously adjusting the constructed portion as permitted by rule 11.2.20.

11.3. Construction Site

See the “Site Plan” on the “Site and Bridge” diagram for layout of the construction site. The host student organization lays out the site, including the one-foot by one-foot footings, before the competition.

Only builders and judges are permitted within the boundaries of the construction site during timed construction. Only judges are permitted near the construction site. Spectators, including faculty advisers, must observe from areas designated by the judges and host student organization.

11.4. Start

Before construction begins, all of the following items, and nothing else, are in the staging yards: members, fasteners, tools, and temporary piers (if used). Every member, tool, temporary pier, and fastener must be in contact with the ground. Members must not be connected or touching one another. Tools and fasteners must not be in contact with members. Tools must not be in contact with fasteners. Temporary piers must not be in contact with one another nor with members, tools, or fasteners. Builders who are not barges are in the staging yards, and the barge or barges (if used), but nothing else, are in the river. Barges start without tools and fasteners, which may be passed to them by other builders after timed construction begins. Builders, including barges, are wearing personal protective equipment as well as optional clothing such as pouches.

During timed construction, additional builders, members, tools, fasteners, temporary piers, or other items must not be brought into the construction site nor must anything be removed.

Timing and construction begin when one of the builders signifies that the team is ready and the judge declares the start.

11.5. Time

Time is kept from start to finish of construction. The clock will be stopped under the following conditions

- 11.5.1. if a builder or judge sees a condition that could cause injury, or
- 11.5.2. when a safety rule has been violated (see section 11.2), or
- 11.5.3. when work has been accomplished by committing an “accident.” The clock is not stopped if the “accident” does not contribute to the construction process (see section 11.7).

Construction ceases while the clock is stopped. After the situation has been corrected, builders, tools, temporary piers, and bridge components are returned to the positions they occupied before the interruption, and the clock is restarted.

11.6. Time Limit

- 11.6.1. If construction time exceeds 30 minutes but does not exceed 45 minutes, it will be multiplied by 1.50 for scoring. Judges will inform the team when this limit is reached.
- 11.6.2. If construction time exceeds 45 minutes, it will be counted as 180 minutes for scoring. “Accidents” (section 11.7) that occur after 45 minutes will not be penalized but safety rules (section 11.2) will still be enforced. Judges will inform the team when this limit is reached.
- 11.6.3. If construction time exceeds sixty minutes, judges may halt construction, or may move the bridge off site if it can be completed safely. The bridge will not be eligible for awards in any category.

11.7. Accidents

In general, the clock is not stopped when an “accident” occurs. If an accident is continuous (for example, a builder who is not a barge stands in the river) it will be counted as multiple incidents. Builders involved in accidents may continue to build, and items involved in accidents must be recovered promptly and may be used.

Construction cannot depend on deliberately committing an accident. Therefore, the clock will be stopped if any work is accomplished by committing an accident. Before timed construction is resumed, builders, tools, members, assemblies, temporary piers, and fasteners will be returned to the positions they occupied before the accident. Exception: Construction may proceed if it is no longer possible to hold all four bearing surfaces within the footings simultaneously. In this situation, the team captain may request that the clock be stopped in order to demonstrate the difficulty to the judge. If the judge is convinced, no additional accidents will be cited for bearing surfaces touching the ground outside the footings (rule 11.7.3), the clock will be restarted, construction will resume, and a penalty will be assessed for a dimensional violation under rule 9.2.1 (even if the bearing surfaces fall within the footings when the bridge is completed).

Types of accidents and the corresponding time penalties, which will be added to the construction time, are

11.7.1. A builder who is not a barge or that builder’s clothing touches the river or floodway. Penalty is 1/2 minute (thirty seconds) per incident. Exception: There is no penalty for entering the river or floodway to retrieve an object that has been dropped, such as a member, tool, nut, bolt, or hardhat.

11.7.2. A barge or a barge’s clothing touches ground (which includes the floodways). Penalty is 1/2 minute (thirty seconds) per incident. Exception: There is no penalty for stepping on ground to retrieve an object that has been dropped, such as a member, tool, nut, bolt, or hardhat.

11.7.3. A member, assembly, or constructed portion touches the river or ground outside a staging yard. Penalty is 1/4 minute (fifteen seconds) per incident. Exception: There is no penalty for members, assemblies, and the constructed portion touching the ground within the one-foot by one-foot footings.

11.7.4. A tool, nut, bolt, hardhat, goggles, or protective eyewear touches the river or ground outside a staging yard. Penalty is 1/4 minute (fifteen seconds) per incident. Exception: There is no penalty if a tool used exclusively for measuring touches the ground during use while being held by a builder.

11.7.5. A member, assembly, or tool touches a revetment. Penalty is 1/4 minute (fifteen seconds) per incident.

11.7.6. A builder steps or jumps on or over a revetment. Penalty is 1/4 minute (fifteen seconds) per incident. However, a builder may go around the end of a revetment, reach over a revetment, and pass members, assemblies, temporary piers, tools, and fasteners over a revetment without penalty.

11.7.7. A barge crosses over or under any part of a constructed portion. Penalty is 1/4 minute (fifteen seconds) per incident. However, a barge may reach and pass objects under, over, or through the constructed portion without penalty.

11.7.8. A builder steps outside the boundary of the construction site. Penalty is 1/4 minute (fifteen seconds) per incident. Exception: There is no penalty for stepping outside the construction site to retrieve an object that has been dropped such as a member, tool, nut, bolt, or hardhat.

11.8. Finish

Construction ends and the clock is stopped when

- the bridge has been completed by connecting all the members, and
- all tools, temporary piers (if used), and builders who are not barges are back in the staging yards, and
- the barges are in the river and not in contact with the bridge, and
- one of the builders signifies that they are finished.

Installation of decking is not included in timed construction.

After construction is finished the bridge must not be modified except as provided by section “11.9 Construction: Repairs.”

11.9. Repairs

Before the judges inspect and measure the bridge, and before the bridge is moved from the construction site, two builders will be given five minutes to inspect the bridge for construction mistakes and to plan corrective action. They must not modify the bridge and they must not touch the bridge except as necessary to use measuring devices. Following this inspection, builders will be permitted, but not required, to repair construction mistakes found by their inspectors. Repairs are made with the clock restarted and must be completed in ten minutes or less. Safety precautions (section 11.2) apply and accidents (section 11.7) are counted. The time required to make repairs (including penalties) is multiplied by 1.5 and added to the construction time. Judges will not inspect the completed bridge for violations of rules until after the team captain is satisfied or the time limit for repairs is reached.

12. LOAD TESTS

12.1. Safety Precautions

The judge will halt any activity that is hazardous.

A bridge could suddenly collapse or sway in any direction during load tests. Therefore, minimize the number of people near the bridge while it is being tested. Usually, the load should be placed on the bridge by only two members of the team. Team members who are not participating in loading, faculty advisers, and other spectators must observe from an area designated by the judges and host student organization.

While participating in load testing, competitors must wear hardhats meeting ANSI standard Z89.1, protective eyewear or safety goggles meeting ANSI standard Z87.1, gloves, and leather construction boots. This safety equipment is provided by the competitors. Judges will not permit load testing by competitors who are not wearing the specified safety equipment or are wearing it improperly.

During testing, safety supports must be in place below the decking. The safety supports should be of sufficient height, strength, number, and extent that none of the load will fall more than approximately six inches if the bridge collapses.

Do not exceed 400 psf uniform load or 500 pounds concentrated load on the decking. Do not load on a portion of the decking that is cantilevered over its support.

When any portion of the load is on the bridge, no one is permitted to crawl, reach, or step under the bridge. If such an action is necessary, the load must first be removed.

12.2. Damage

A bridge will not be tested in a condition that compromises its strength or stability.

If a nut falls off its bolt while the bridge is being transported or prepared for load testing, or if the threads of a nut are not fully engaged, the connection will be repaired, the nut will be installed, and a penalty of two minutes will be added to construction time.

A bridge with irreparable damage that would reduce its strength or stability (such as a missing or broken member or fastener) will not be approved for load testing and is not eligible for awards in any category.

12.3. Preparation

Temporary piers are not used during load testing.

The judge designates the “A” and “B” sides of each bridge by a random process. “Left” and “right” ends are determined by facing the “A” side.

“Sway” is translation in any horizontal direction. A target is established for sway measurement on the “A” side of the bridge, ten feet from the left end of the decking support surface on that side. The sway target is located at the level of the decking support surface, which is the same as the bottom of the decking. See the “Lateral Load Test” plan on the “Bridge Loading” diagram.

Three targets are established for measuring vertical deflection. Two of the vertical deflection targets are located longitudinally at the center of the left unit of decking, on the “A” and “B” sides of the bridge, at the level of the decking support surface, which is the same as the bottom of the decking. The other vertical deflection target is located longitudinally at the center of the right unit of decking, on the “A” side of the bridge, at the level of the decking support surface. Targets may be on the decking or on the bridge. For location of decking units, see section 12.5 and the “Location of Targets and Decking” plan on the “Bridge Loading” diagram.

At their discretion, judges may impose a penalty for a bridge that incorporates parts having the primary function of interfering with placement of targets or measuring equipment.

Teams must accept imperfect field conditions such as bent decking and slightly sloping floors.

12.4. Lateral Load Test

The provisions of this section are illustrated by the “Lateral Load Test” plan on the “Bridge Loading” diagram.

The lateral load test is conducted with one unit of decking placed at the center of the bridge and approximately 75 pounds of weight on the decking near the “B” side of the bridge. This load is intended to prevent the bearing surfaces of the bridge from lifting off the ground when lateral load is applied.

The two bearing surfaces on the “B” side of the bridge are prevented from sliding by horizontal restraint applied from the inside of the abutments as close as possible to the ground. This horizontal restraint does not restrain rotation of the abutments and is identical for all bridges.

Apply a fifty-pound lateral pull at the sway target and measure the sway. To pass the lateral load test, the sway must not exceed one inch.

If the bridge did not pass the lateral load test it is not approved for further testing. **Do not conduct any other load test.** Add a penalty of 900 pounds to the weight of the bridge and a penalty of thirty minutes to the construction time. Record: Aggregate deflection = sixty inches.

If the bridge passed the lateral load test, remove the load and decking, and proceed with the vertical load test.

12.5. Vertical Load Test

The provisions of this section are illustrated by the three “Vertical Load Test” elevations on the “Bridge Loading” diagram.

Safety supports are placed under the decking so that no portion of the load will drop more than approximately six inches if the bridge collapses.

Decking units are three feet long in the longitudinal (span) direction of the bridge. Place the two decking units at distances L1 and L2 measured from the left end of the decking support surface on the “A” side of the bridge to the left edges of the decking units. See item 4 in chapter 8 for determination of L1 and L2, and section 12.3 for location of targets. Decking units are placed square with the bridge, with the main bars spanning laterally over the decking support surfaces, and centered on the designated nominal centerline (see section 9.3). Decking units must not be attached to the bridge and must not distort it (see rules 9.1.4 and 9.1.5).

Position measuring devices on the three vertical deflection targets.

Uniformly distribute 100 pounds of preload on the left decking unit and uniformly distribute 100 pounds of preload on the right decking unit. Preloads are laterally centered on the decking units. Preloads are distributed and aligned identically for every bridge.

If a contestant disturbs a measuring device after it has been initialized and before the measurement is recorded, the judge will require the team to disassemble the bridge and repeat timed construction. Scoring will be based on the larger of the two construction times but will not exceed 125% of the initial construction time.

The two steps (increments) of vertical loading produce three measurements used in scoring

- D1A = value of downward vertical deflection at left target on the “A” side that occurs during step 1 (loading on left decking unit).
- D1B = value of downward vertical deflection at left target on the “B” side that occurs during step 1 (loading on left decking unit).
- D2 = value of downward vertical deflection at right target that occurs during step 2 (loading on right decking unit with load from step 1 remaining in place).

Step 1

Loading the left unit and measuring deflections at those targets

- The two 100-pound preloads remain in place.
- Initialize the sway measurement.
- Initialize the measuring devices on all three vertical deflection targets or record the initial readings.
- Team members place 1150 pounds of additional load on the left decking unit. The load is laterally centered on the decking unit and is distributed over the length of the decking unit as uniformly as possible at all times during loading. Load is distributed and aligned identically for every bridge. Load should be placed at a steady pace, without hesitation.
- As the load is being placed, observe sway and deflection. Stop loading if
 - a. sway exceeds one inch, or
 - b. deflection measurement at any of the three vertical deflection targets exceeds two inches downward, or
 - c. decking or any part of the bridge, other than the intended bearing points, comes to bear on a safety support or the floor, or
 - d. a decking unit falls off the bridge, or
 - e. a dangerous collapse is imminent, in the opinion of the judge.

If sway or deflection is excessive (situation a or b), the bridge is not approved for further load testing. Remove the load and **do not continue load testing**. Add an 800-pound penalty to the weight of the bridge and a penalty of thirty minutes to the construction time. Record: Aggregate deflection = sixty inches.

If the bridge fails (situation c, d, or e), it is not approved for further load testing and is not eligible for awards in any category. Remove the load and **do not continue load testing**.

If the bridge passes step 1, record the measured values D1A and D1B, which are the downward vertical deflections during step 1 of the two targets for the left decking unit.

Step 2

Loading the right unit and measuring deflection at that target

- The two preloads and the load from step 1 remain in place.
- Do **not** re-initialize the sway measurement.
- Do **not** re-initialize the measuring devices on the left deflection targets.
- Initialize the measuring device on the right vertical deflection target or record the reading.
- Team members place 1150 pounds of additional load on the right decking unit. The load is laterally centered on the decking unit and is distributed over the length of the decking unit as uniformly as possible at all times during loading. Load is distributed and aligned identically for every bridge. Load should be placed at a steady pace, without hesitation.
- As the load is being placed, observe sway and deflection. Stop loading if
 - a. sway exceeds one inch, or
 - b. deflection measurement at any of the three vertical deflection targets exceeds two inches downward, or
 - c. decking or any part of the bridge, other than the intended bearing points, comes to bear on a safety support or the floor, or
 - d. a decking unit falls off the bridge, or
 - e. a dangerous collapse is imminent, in the opinion of the judge.

If sway or deflection is excessive (situation a or b), the bridge is not approved for further load testing. Remove the load and **do not continue load testing**. Add a 700-pound penalty to the weight of the bridge and a penalty of thirty minutes to the construction time. Record: Aggregate deflection = sixty inches.

If the bridge fails (situation c, d, or e), it is not approved for further load testing and is not eligible for awards in any category. Remove the load and **do not continue load testing**.

If the bridge passes step 2, record the measured value $D2$ = value of downward vertical deflection during step 2 of the target for the right unit of decking. Compute and record: Aggregate deflection = $D1A + D1B + D2$.

12.6. Unloading

If the bridge collapses during unloading, it is not eligible for awards in any category.

13. EQUIPMENT PROVIDED BY HOST

The web site <http://www.nssbc.info> has detailed descriptions and illustrations of hosting equipment. The following partial list is intended to help competitors know what to expect. Competitors should acquire similar equipment for use in practice and testing before the competition.

13.1. Lateral Load Device

Capable of applying a 50-pound force in the horizontal direction.

13.2. Equipment for Measuring Sway

Sway is horizontal translation and is measured by any accurate method. A suggested method is to suspend a plumb bob from the sway target and measure sway from a point marked on the ground.

13.3. Equipment for Measuring Deflection

Deflection is vertical translation and is measured at three points by any accurate method.

13.4. Decking

Preferred decking is steel bar grating identified as W-19-4 (1 x 1/8). The dimensions of a unit of grating are approximately 3'6" x 3'0" x 1" and the weight is approximately fifty pounds. However, the host may provide a different type of decking with approximately the same dimensions. Grating has significant bending strength only in the direction of the main bars, which are 3'6" long. The grating will be installed with the main bars perpendicular to the length of the bridge, creating a roadway that is 3'6" wide. Therefore, support for the grating is needed for the edges that are parallel to the length of the bridge but not for the edges of the grating that are perpendicular to the length.

13.5. Load

2500 pounds total. The load should be supplied in uniform pieces of size and weight that can be handled safely. When in place, the load should not provide significant stiffness in the longitudinal direction of the bridge. The recommended load consists of 25-pound lengths of 5" x 5" x 5/16" steel angle placed perpendicular to the length of the bridge. Sacks of material, containers of liquid, concrete blocks, or jacking systems could be used. Decking is not included as part of the 2500 pound load.

13.6. Safety Supports

The safety supports must be used during load testing and are intended to limit the consequences of a bridge collapsing. The safety supports should be of sufficient height, strength, number, and extent so that none of the load will fall more than approximately six inches if the bridge collapses. Safety supports may be steel, nested stacks of plastic buckets, timbers, sand bags, or masonry units.

13.7. Floor

The surfaces on which the bridges will bear should be as nearly flat and level as possible, in both the construction site and loading area.

13.8. Revetments

Revetments should be 1'6" to 2'6" high, ten feet long, and no thicker than one foot. Examples of adequate revetments include caution tape stretched between supports, mesh fencing, wood-framed knee walls, or insulation panels.

13.9. String

A string is stretched between the holes specified in section 9.3 in order to identify the nominal centerline of the bridge, which guides checking dimensions (rules 9.2.4, 9.2.5, 9.2.6, and 9.2.14) and placing the decking and load (rule 12.5).

14. INTERPRETATION OF RULES

The web site <http://www.aisc.org/steelbridge.html> lists answers to questions about the rules. Competitors, judges, and host personnel may submit questions via a form on that web site but should **first read the previously posted clarifications and reread this *Rules* document carefully in its entirety**. The names of submitters and their affiliations will be posted with their questions. Questions must be submitted before 5:00 PM Eastern Daylight Saving Time, 12 May 2008.

15. JUDGING

The host student organization will recruit judges. Judges are empowered to halt any activity that they deem to be hazardous. Judges have full authority over conduct of the competition and interpretation of the rules. Decisions, scoring, and ranking are the sole responsibility of the judges and will be final. The host student organization will assure that the judges are fully informed of the rules and procedures, and fully equipped for their tasks. More information for host organizations and judges, including the official scoring spread sheet, is available at <http://www.nssbc.info> and <http://www.aisc.org/steelbridge.html>.

16. APPEALS

16.1. Regional Competitions

16.1.1. At the beginning of the competition each team will identify the team member who serves as captain. The host organization will identify the regional head judge (RHJ).

16.1.2. A penalty, decision, measurement, score, or condition of competition may be appealed only by a team captain and only to the RHJ. The appeal must be made as soon as possible after the situation becomes apparent. The RHJ will not hear the appeal if he or she is approached by students other than the team captain. The RHJ will hear the appeal as soon as possible and may interrupt the competition. Participants are reminded that civility and ethical behavior are expected during the competition and particularly concerning appeals.

16.1.3. After the regional competition, the team captain has the option to appeal the decision of the RHJ by sending an e-mail message to Mr. Fromy Rosenberg <rosenberg@aisc.org> followed by a letter mailed to Mr. Rosenberg (AISC, Suite 700, One E. Wacker Dr., Chicago, IL 60601-2001) with a copy mailed to ASCE Student Services (ASCE, 1801 Alexander Bell Dr., Reston, VA 20191-4400). The e-mail message and letter should include

- name of the college or university making the appeal,
- team captain's name, e-mail address, postal address, and telephone number,
- faculty adviser's name, e-mail address, postal address, and telephone number,
- brief description of the problem,
- action taken at the competition to deal with the problem,
- action that the appealing team feels should have been taken,
- data showing that the team should have qualified for national competition, and
- team captain's signature (letter only).

Appeals must be made by e-mail followed by letter. An appeal will be considered only if the e-mail is received and the letter is postmarked within **one week** after the regional competition. Mr. Rosenberg will forward the appeal to the ASCE/AISC Rules Committee for their evaluation. The only redress that may be made is an invitation to participate in the national competition if the Rules Committee is convinced that the appeal is valid and that the appealing team should have qualified for the national competition. Decisions and rankings made by regional judges will not be overturned.

16.2. National Competition

16.2.1. Judges will refuse to hear protests from a team concerning any bridge other than their own.

16.2.2. A penalty, decision, measurement, score, or condition of competition may be appealed only by a team captain and only to the station head judge (SHJ). The SHJ will not hear the appeal if he or she is approached by students other than the team captain. The appeal must be made as soon as possible after the situation becomes apparent and before the conditions at issue are changed (e.g., by further construction, loading, or disassembly of the bridge). The SHJ will hear the appeal as soon as possible and will make a ruling. The conditions at issue will not be changed during deliberation. Participants are reminded that civility and ethical behavior are expected during the competition and particularly concerning appeals.

16.2.3. After hearing the SHJ's ruling, the team captain may request a five-minute recess to discuss the issue with the team. During the recess, the conditions at issue will not be changed. Immediately after that recess, if the team has justification to contest the SHJ's ruling, the captain has the option to appeal that decision to the national head judge (NHJ). The NHJ will hear the appeal as soon as possible and will make a ruling. The NHJ may consult with the ASCE/AISC Rules Committee. The conditions at issue will not be changed during deliberation.

16.2.4. If the team has justification to contest the NHJ's ruling, the team captain has the option to appeal that decision directly to the ASCE/AISC Rules Committee within fifteen minutes after hearing the NHJ's ruling. The Rules Committee may request information from the NHJ and SHJ but those judges will not vote on the final ruling.

16.2.5. The decision of the ASCE/AISC Rules Committee is final; there are no further appeals. However, AISC and ASCE welcome written suggestions for improving future competitions.

17. SUMMARY OF SCORING

This form summarizes chapter "7 Scoring." Official scoring data should be recorded on the official scoring spreadsheet that is available at <http://www.nssbc.info>. The completed official scoring spread sheet should be submitted to aftbq@uaa.alaska.edu.

17.1. Display (see section 7.1 - Judges should not declare ties in display.)

- Appearance: balance, proportion, elegance, finish.
- Name of college or university on bridge in letters at least one inch high.
- Poster describing design and fabrication, no larger than 2 x 3 feet.

DISPLAY SCORE = _____

17.2. Construction Speed and Time Penalties

Construction clock time, CT	_____	minutes
If CT ≤ 30 minutes, enter CT		
If 30 < CT ≤ 45, multiply CT by 1.5 (see 11.6)		
If 45 < CT ≤ 60, enter 180 (see 11.6)		_____ minutes
Time penalties during construction (see 11.7)		
11.7.1,2: violations _____	x 1/2	+ _____ minutes
11.7.3,4,5,6,7,8: violations _____	x 1/4	+ _____ minutes
Repair time (see 11.9) _____	x 1.5	+ _____ minutes
Time penalties during repair (see 11.7, 11.9)		
11.7.1,2: violations _____	x 1/2 x 1.5	+ _____ minutes
11.7.3,4,5,6,7,8: violations _____	x 1/4 x 1.5	+ _____ minutes
Time penalty, damage (see 12.2)		+ _____ minutes
Time penalty, load tests, 30 min (see 12.4 and 12.5)		+ _____ minutes
TOTAL TIME =		_____ minutes
Lowest total wins.		

17.3. Construction Economy

Number of builders, including barges	(_____	persons
Total time (part 17.2)	x _____	minutes
	x <u>50</u>)
Number of moves of temporary piers (see 11.1.8)	+ (_____	
	x <u>20</u>)
Number of barges (0, 1 or 2)	+ (_____	
	x <u>30</u>)

CONSTRUCTION COST: C_c = _____ thousand \$
Lowest cost wins.

17.4. Lightness and Weight Penalties

Bridge weight _____ pounds
 Weight penalties,
 “7.1 Display” (50 or 100) + _____ pounds
 “9.2 Dimensions and Support: Usability”
 Rules violated ≤ ½ inch _____ x 50 + _____ pounds
 Rules violated ½ - 1 inch _____ x 150 + _____ pounds
 Rules violated 1 - 2 inch _____ x 300 + _____ pounds
 “9.3 Dimensions and Support: Centerline” (100) + _____ pounds
 “10.2 Material & Components: Durability & Constructability”
 Number of violations _____ x 10 pounds + _____ pounds
 Wt. of parts in violation _____ pounds x 5 + _____ pounds
 “12.4 and .5 Load Tests: Lateral Load and Vertical Load”
 (900, 800 or 700) + _____ pounds

TOTAL WEIGHT = _____ pounds
 Lowest weight wins.

17.5. Stiffness

AGGREGATE DEFLECTION: D1A + D1B + D2 = _____ inches
 Lowest deflection wins.

17.6. Structural Efficiency

Total weight (part 17.4) (_____ pounds
 x _____)
 Aggregate deflection (part 17.5) + (_____ inches
 x _____)

STRUCTURAL COST: C_s = _____ thousand \$
 Lowest cost wins.

17.7. Overall Performance

C_c (from part 17.3) _____ + C_s (from part 17.6) _____ = _____
 Lowest total wins.

17.8. Ranks (Display is the tie-breaker for all categories)

A bridge will not be ranked if it was not approved for construction or load testing,
 or if it failed in load testing.

Display _____ Construction Speed _____ Lightness _____
 Stiffness _____ Construction Economy _____ Structural Efficiency _____
 Overall Performance _____

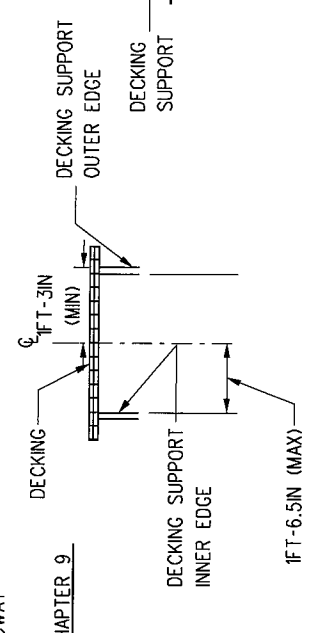
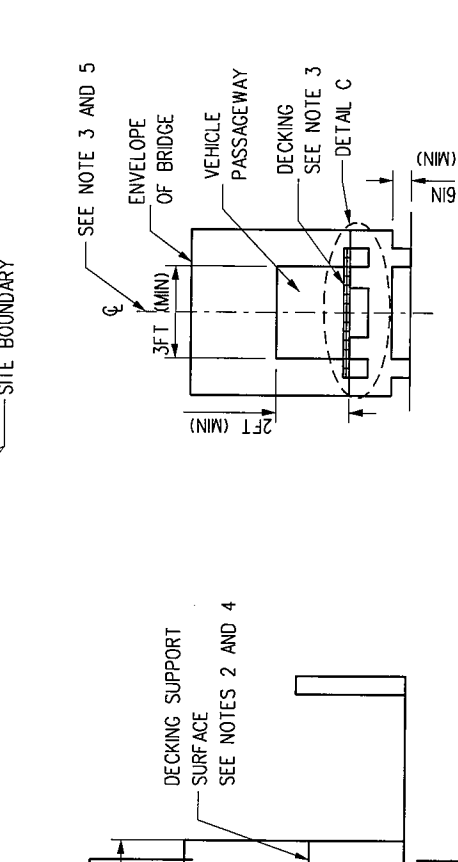
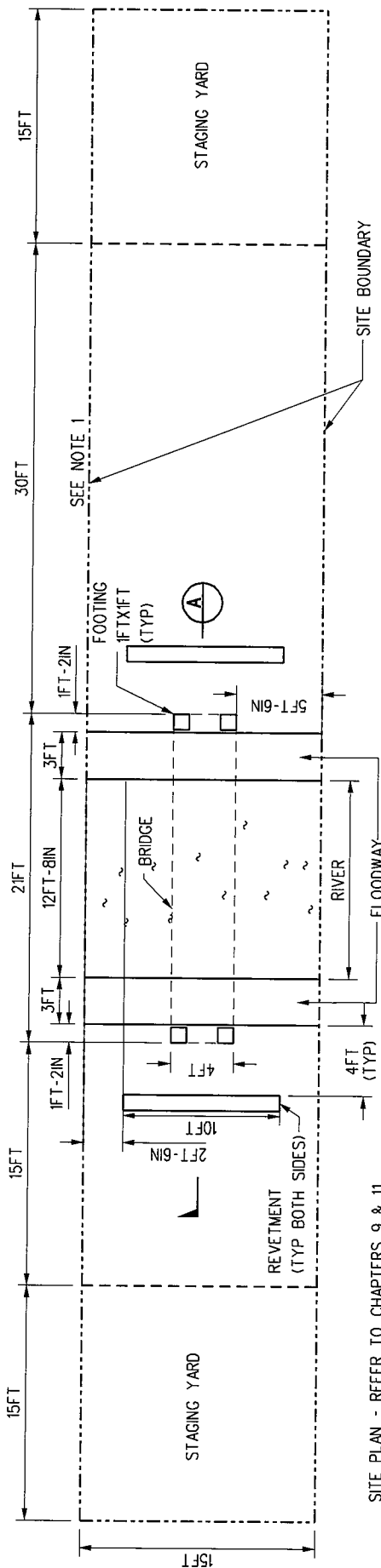

NOTE: 1. LENGTH CAN BE ADJUSTED TO FIT SITE CONDITIONS.
 2. TOP OF THE DECKING SUPPORT SHALL BE BETWEEN 2 FT - 3 IN AND 2 FT - 6 IN ABOVE GRADE.
 3. BRIDGE SHALL ACCOMMODATE 3 FT - 9 IN DECKING THROUGHOUT
 OVERALL LENGTH OF THE BRIDGE IN ACCORDANCE WITH RULE 9.2.4.
 4. NO PART OF BRIDGE SHALL EXTEND BEYOND DECKING SUPPORT SURFACE (AT BOTH ENDS).
 5. DIMENSIONS ARE CENTERED ON BRIDGE CENTERLINE.

SCALE: NONE
 IRREGULARITIES IN DECKING SUPPORT - REFER TO CHAPTER 9

REV	DATE	BY	APP	REV NO	CHANGES	SCALE	DESCRIPTION
A	6-12-07						

DESIGNED BY	DRAWN BY	CHECKED BY	IN CHARGE	DATE
E. HAIFIELD	D. SEPULVEDA	RULES COM.	F. ROSENBERG	6-11-2007

ASCE - AISC
 STUDENT STEEL BRIDGE CONTEST





CONTRACT NO.	DRAWING NO.	EXHIBIT	SCALE	SHEET NO.
		I	AS SHOWN	

SITE AND BRIDGE
 DIAGRAM

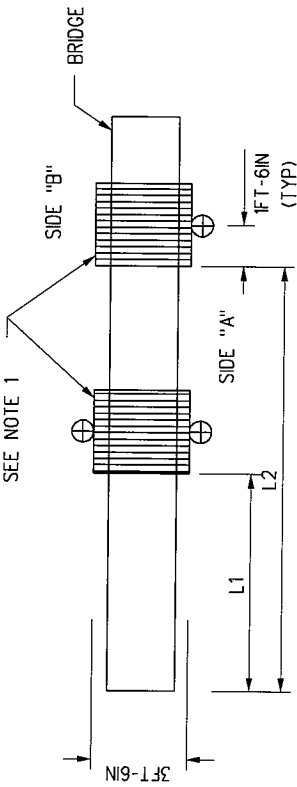
DECKING UNITS
SEE NOTE 1

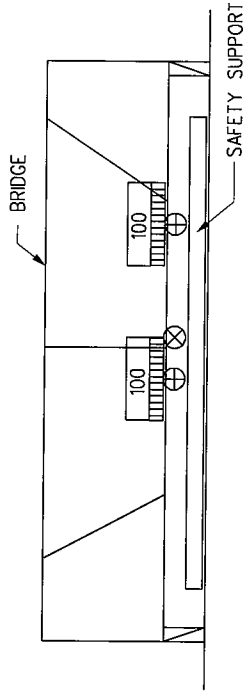

A LOCATIONS OF TARGETS AND DECKING - PLAN
REFER TO CHAPTER 12, SECTIONS 3 & 5



0 VERTICAL LOAD TEST - PRELOAD
REFER TO NOTES DURING LOADING PROCESS

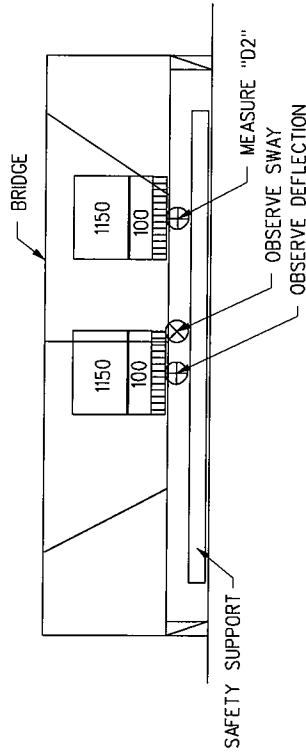

1 VERTICAL LOAD TEST - STEP 1
REFER TO NOTES DURING LOADING PROCESS

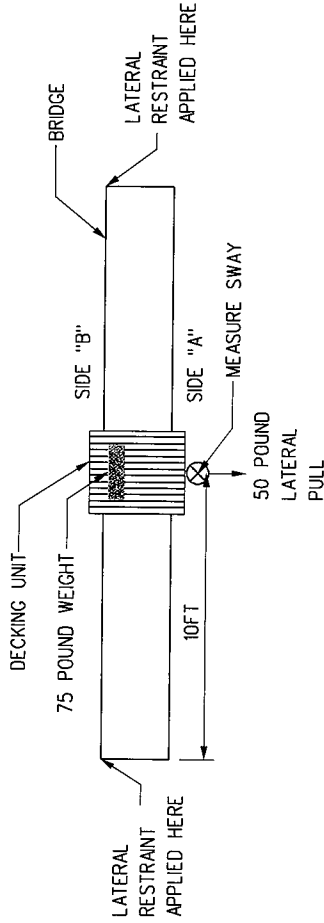

B LATERAL LOAD TEST - PLAN
CHAPTER 12, SECTIONS 3 & 4

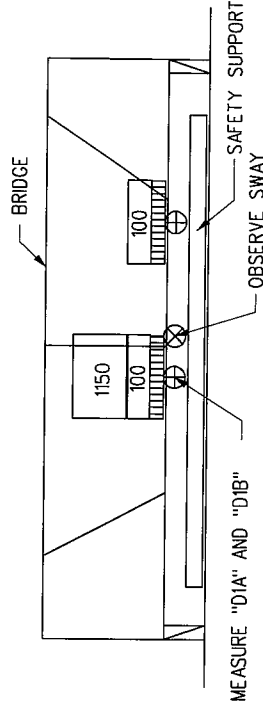

2 VERTICAL LOAD TEST - STEP 2
REFER TO NOTES DURING LOADING PROCESS

LEGEND

- ⊕ TARGETS FOR MEASURING VERTICAL DEFLECTION TO BE PLACED LONGITUDINALLY AT THE CENTER OF THE DECKING UNITS
- ⊗ TARGET FOR MEASURING SWAY

NOTES

1. THE LOAD IS Laterally CENTERED ON THE DECKING UNIT AND DISTRIBUTED OVER THE LENGTH OF THE DECKING UNIT AS UNIFORMLY AS POSSIBLE AT ALL TIMES DURING LOADING.
2. OBSERVE ALL VERTICAL TARGETS ON EACH SIDE OF THE BRIDGE FOR DEFLECTION.
3. LOADING TERMINATES IF DEFLECTION AT ANY OF THE VERTICAL DEFLECTION TARGETS EXCEEDS 2 INCHES DURING STEP 1 AND STEP 2.
4. LOADING TERMINATES IF SWAY AT SWAY TARGET EXCEEDS 1" DURING STEP 1 AND STEP 2.
5. SAFETY SUPPORT TO BE IN PLACE AT ALL TIMES DURING LOADING.
6. BRIDGE TO BE UNLOADED IN THE REVERSE ORDER OF LOADING.
7. ALL LOADING SAFETY PROCEDURES TO BE FOLLOWED.

REV	DATE	BY	APP	INC NO	COPIES	SER. NUMBER	DESCRIPTION
A	6-12-07						2008 SSSC RULES
DESIGNED BY		CHECKED BY		ORDERED BY		RULES COM.	
F. HAIFIELD		D. SEPULVEDA		F. ROSENBERG		6-11-2007	
ASCE - AISC STUDENT STEEL BRIDGE CONTEST				BRIDGE LOADING DIAGRAM			
ASCE American Society of Civil Engineers				AS SHOWN			
SUBMITTED				EXHIBIT 2			
APPROVED				CONTRACT NO.			