



A new retail project
near Times Square
demonstrates the
hipness of being square.

Thinking Outside the CUBE

BY JOE MUGFORD, PE, AND PHILIP MURRAY, PE

Images this spread: Courtesy of MdeAS Architects

A DRAMATIC RETAIL NEWCOMER of cubic proportions has come to Manhattan's 42nd Street commercial corridor.

Known as the Cubes, the project flanks the western edge of a through-block plaza at 120 West 42nd Street between Avenue of the Americas and Broadway. Its design employs several distinct boxes shifted in relation to one another while maintaining the uniformity of its grid, and contrasts with the monolithic character of the adjacent 1095 Avenue of the Americas tower (also known as 3 Bryant Park). Framed with 400 tons of structural steel, the 85-ft-tall structure comprises three occupied floors, as well as a fourth-floor mechanical penthouse, and contains approximately 23,000 sq. ft of above-grade retail space and an additional 55,200 sq. ft below grade in the cellar and sub-cellar. The protruding blocks provide an additional 4,300 sq. ft of accessible rooftop exterior space. The design relocated the main entrance to the 1095 tower from the Avenue to the west side of the building (plaza-side) where a new double-height lobby was constructed. Relocating the entrance allowed for additional retail space along the Avenue. The existing sub-

way entrance was repositioned away from the plaza corner to allow prime retail use of that space.

Jewel Box

Glass curtain walls, wide interior spans and lots of right angles make the interior spaces light-filled and engaging. Across the plaza, this approach is mimicked at the interior of the existing 1095 tower. From the street, the structure looks like two separate buildings, but the two sides are actually united underground.

The ground-up development required demolition of a six-story 1940s building. Additionally, part of an existing annex building was demolished to grade, but its substructure was preserved and engaged by the new superstructure. Drawings for the existing building lacked the appropriate level of details and demanded extensive field verification. The 1970s design of the existing annex building, which was partially demolished, assumed subsequent addition of more floors. Thus, the preserved substructure did not require much reinforcement, as columns were already oversized, and reserve capacity was therefore available to support the new



▲ ▶ Setbacks and the mechanical penthouse.



- ◀ Southwest view from 42nd Street.
- ▶ Rendering of project components (looking south from 42nd Street).



design. However, the column grid of the new superstructure does not align with the grid of the substructure, so the design employs W30×173 transfer girders at the plaza level that distribute the load to the foundation. The new foundation system consists of spread footings on 20-ton rock. The challenging excavation and foundation work included digging 32 ft below street level adjacent to the operational 42nd Street MTA subway tunnel, with careful attention to earthwork vibration. The dig took place around existing W14 columns, which had to be temporarily supported with drilled piles.

The open layout of the retail floor plates above grade required a long-span column grid, typically 25 ft by 45 ft. With 20-ft floor-to-floor heights, careful consideration of live loads and vibrations demanded stiffer frames. The entire superstructure is designed using moment frames to maintain an open layout for future retail flexibility, and floor vibrations for occupant comfort were taken into consideration in the design of the structure. In accordance with AISC Design Guide 11: *Vibrations of Steel-Framed Structural Systems Due to Human Activity*, these vibrations were limited to a maximum of 1.5% gravity acceleration at



Joe Mugford (joe.mugford@gmsllp.com) is an associate and **Philip Murray** (philip.murray@gmsllp.com) is a partner, both with Gilsanz Murray Steficek.



▲ Substructure. ▼ Superstructure. ➤ A bent girder.



Photo by GMS



Photo by GMS



Courtesy of MdeAS Architects



▲ Westward view of plaza.
 ▼ Northwest view of plaza.
 ➤ Schematic of frame reinforcement at lobby.

2% damping. (You can read more about the new edition of Design Guide 11 in “Living (Comfortably) with Vibration” on page 58.)

The primary W14×193 and W14×283 moment frame columns are set back 14 ft from the east façade, and round 10-in. hollow structural sections (HSS) were used along the east façade to minimize their visual impact. The floor framing consists of typical W18×35 beams spanning to 30-in. and 36-in. girders, and floor slabs are 3.5-in. lightweight concrete on 3-in. metal deck. The structure is designed to support a 60-ft billboard above the roof as well as a full-span LED display anchored to the north façade, a nod to the Times Square lighting requirements.

Planted Plaza

Another design challenge was accommodating the change in grade at the perimeter of the site. The elevation of the northern section of the renovated plaza is 3 ft higher than the ground

floor elevation of the Cubes. Structural engineer GMS designed a series of “bent” transfer girders to maximize the retail ceiling heights below. The plaza renovation also demanded careful attention to the design and installation of tree pits so as not to encroach on floor-to-ceiling heights below. The bottom of the 9-in. pit slab is flush with the bottom flange of neighboring W36 and supported by L3 angles welded to either side of HSS9×5×½, which spans in between existing W36 beams at 3 ft, 6-in. on center. This provided adequate support for the weight of the soil and trees, which required a design load of 600 psf.

Approximately 30 ft of the southern portion of the prior plaza was demolished and rebuilt at a lower elevation to match the level of the sidewalk at 41st Street. This generated a more inviting space, similar to the pedestrian approach from the north. Planters, stairs and ramps separate the lower southern portions and raised northern portions of the plaza.

Augmented Atrium

Across the plaza from the Cubes, the existing 1095 Avenue of the Americas is a 40-story steel-framed office building, constructed in 1972, with four moment frames in the north-south direction. The westernmost frame (plaza-side façade) needed to be modified to accommodate the relocation and vertical enlargement of the building's main lobby into a 33-ft-high, two-story atrium. The second floor slab was removed at four north-south bays (25 ft each) by one east-west bay (18 ft, 6 in.). Creating the storefront at the lobby also required removing two wind girders at the second floor, which represented 20% of the floor stiffness at that

level. To compensate, the wind girders overhead and in adjacent bays were reinforced, as were the columns that support them. Girders at the second floor are reinforced with 1.125-in. plates at the top and bottom flanges; the third-floor girders are reinforced with WT7×79.5 at bottom flange. Existing built-up columns consist of W14×426 with 6-in. flange cover plates. These were further stiffened with new 2-in. by 18½-in. fitted reinforcing plates added between the flanges, forming a box and providing stiffness necessary to counteract the increased unbraced length. The two end columns that had supported the removed wind girders also have new 1¼-in. flange plates (over the original plates).



▲ The new 1095 Avenue of the Americas lobby from the plaza.

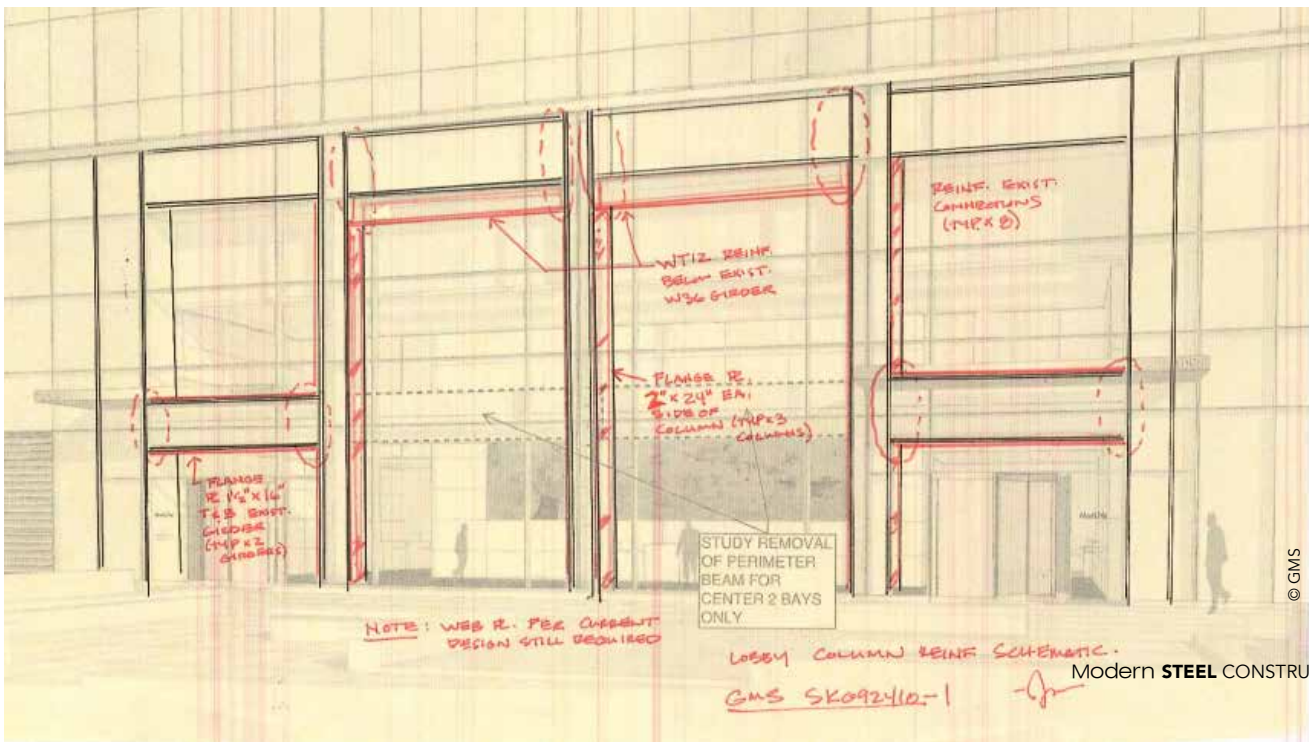

The demolition and installation procedure followed a specific sequence to safeguard the building's ongoing stability during the work:

1. Install column cover plates between the second and third floors
2. Locally remove the slab around the columns and install temporary struts (HSS10)
3. Install a double hanger from temporary struts to the existing east-west beam (W24)
4. Remove a portion of the existing W24 proximate to the western frame
5. Reinforce the perimeter wind girders
6. Complete column reinforcement between first and second floors
7. At the second floor, demolish the remainder of the slab and the W24 beam and temporary strut assemblies

- ◀ Plate reinforcement of lobby columns.
- ▶ Temporary strut assembly for slab and girder removal.

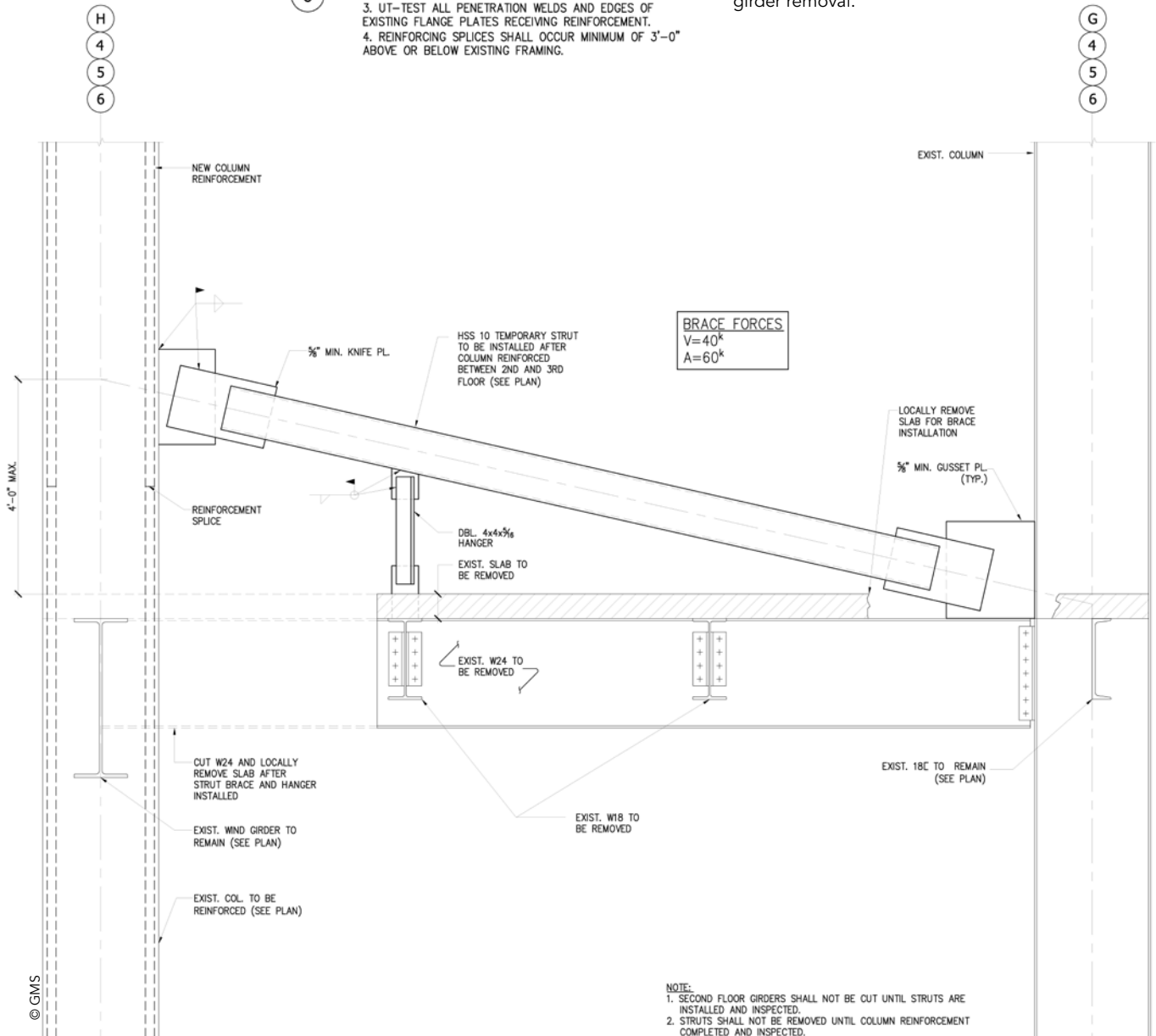
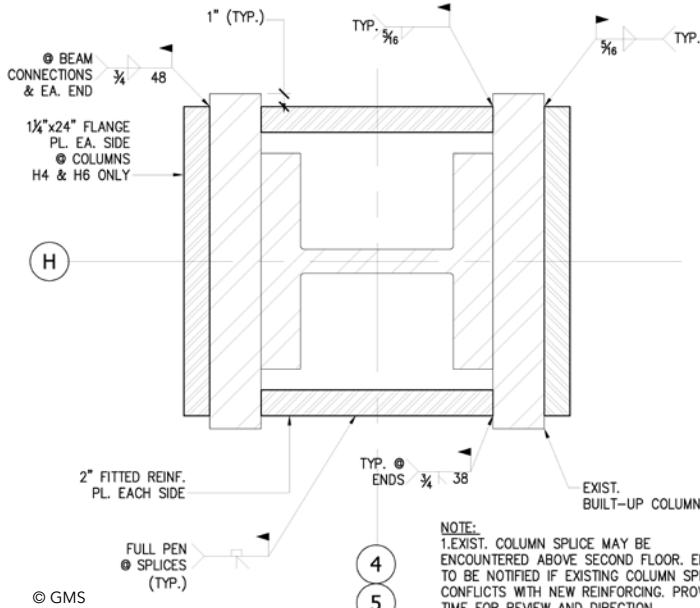



Photo by GMS

▲ A girder before removal...



Photo by GMS

▲ ...and after removal.

Refurbished Retail

The final component of the project was the redevelopment of the 1095 tower's frontage along 42nd Street with a new double-height retail space at the western corner, which connects the street to the concourse beneath the plaza. To the east of this corner space, new stairs and a glass elevator provide access to the subway station beneath the Avenue. However, a moderate elevation difference between where the stairs and elevator land below grade and the entry to the subway station required a ramp structure, which was obstructed by existing framing at the underground concourse level.

Similar to changing the grade between the Cubes and the plaza, a bent beam was installed to support the ramp from a lower elevation. The tops of the existing beams were coped 4 ft from the foundation wall and new 8-ft lengths of beam were added below, bolted to the existing beams' bottom flanges, with a 4-ft overlap. The lower member sits on a channel seat at the foundation wall.

Dramatic Destination

Originally initiated as a plaza restoration, the project was reconceived into a \$22 million white box development (the Cubes) and \$14 million reconstruction (plaza and 1095 tower). In 2015, the entire property consisting of the Cubes and 1095 Avenue of the Americas tower was sold by Blackstone to Ivanhoe-Callahan Capital joint-venture for \$2.2 billion—at that time the largest transaction for a U.S. office building since 2008.

“There is a high demand for new retail space away from the traditional Fifth Avenue shopping district as more brands begin to

scout locations lower on Fifth Avenue or closer to Times Square,” said William Pisani, vice president of Shawmut Design and Construction. Whole Foods is taking two floors of the 1095 tower at the Avenue and Pandora occupies the plaza-side retail corner.

The glass and steel structure solidifies the plaza's prominence as an active destination by surrounding the plaza above and below grade with retail spaces. One of the Cubes' first retail tenants was an Asics store, which incorporated a 7-ton NYC subway car into its space—a unique retail experience for a unique structure. ■

The authors would like to thank Petr Vancura for his help in writing this article.

Developer

Equity Office, New York

Architect

MdeAS Architects, New York

Structural Engineer

Gilsanz Murray Steficek, New York

General Contractors

Shawmut Design and Construction, New York
Structure Tone (plaza), New York

Steel Fabricators, Erectors and Detailers

United Structural Works, Congers, N.Y. 
Burgess Steel, Englewood, N.J. 