

# What Every Fabricator Wants You to Know about Welding

BY MONICA STOCKMANN AND THOMAS J. SCHLAFLY

There are plenty of things that engineers can do to make the welder's work easier and more efficient.

**IF YOU ASKED THE OPINION** of a typical steel fabricator, he or she would probably tell you that there should be a class (or two) in engineering and architecture curriculums that focuses on welding and connection design—from both the engineer's and the fabricator's perspective. However, there's simply no space in the typical curriculum for such a course. To help fill that need, we've developed this article to cover several welding design recommendations from the fabricator's standpoint, including filler metal specifications, preferred weld types, and other applicable weld advice. Obviously we can't cover everything here, so refer to AISC's Design Guide 21, *Welded Connections—A Primer for Engineers*; the American Welding Society 2006 *Structural Welding Code—Steel* (AWS D1.1:2006); and Section J2 of the AISC 2005 *Specification for Structural Steel Buildings* for additional information.

When performed properly, welding is an economical and efficient tool for joining steel. However, welding can become altogether uneconomical when improperly specified. The skilled labor cost required to make a weld typically accounts for 75% to 95% of the total cost of a weld. Thus, cost-effective welding is typically achieved when the required weld metal is deposited in the least amount of time. Here are some tips and highlights on how to design and specify economic welds.

## Welding Processes

In total, there are approximately 100 different welding processes. At present, the steel construction industry uses about five of them: shielded metal arc welding (SMAW); flux cored arc welding (FCAW), which can be gas or self shielded; submerged arc welding (SAW); gas metal arc welding (GMAW); and electroslag welding (ESW). Design Guide 21 describes many of the pros and cons of the different types of welding, as well as several process-specific welding issues, such as applicability of low-hydrogen electrodes in SMAW; the conditions under which short-circuit transfer may occur in GMAW; and the use of active fluxes in SAW.

The choice of welding process can significantly affect the cost of a project. Typically, the contractor makes this important decision, as he or she is usually best positioned to select the optimal welding process for a given application. When properly used, all of the welding processes listed in AWS D1.1 are capable of delivering adequate welds for building construction.

## Over-use of CJP welds

It is common knowledge that complete joint penetration (CJP) groove welds are typically the most expensive type of weld and thus should be reserved for situations in which they are the only viable option. In a CJP groove weld, the full strength of the attached materials is developed. Thus, no design calculations are required when specifying CJP groove welds in statically loaded structures. However, this design advantage can be abused by specifying CJP groove welds in situations where there are better, more economical options. The most commonly abused situation involves longitudinal welds on built-up beam and column sections. These welds are typically loaded in shear, which rarely requires the strength of CJP groove welds. Fillet welds or PJP groove welds are typically better, lower-cost options for this case. Fillet and PJP welds are also typically the more environmentally friendly option, because depositing less metal saves energy too!

## Fillet Welds vs. PJP Groove Welds

A helpful rule of thumb is to use fillet welds whenever the required weld leg size is 1 in. or less, and PJP groove welds or a PJP and fillet weld combination when larger sizes are required. Because most structural steel fillet welds are not required to have leg sizes greater than 1 in., fillet welds are typically the most economical choice, with the exception of skewed T-joints, which must be examined on a case-by-case basis. The table on the next page, taken from Design Guide 21, guides the user through an economical weld selection process based on loading and joint type.

*Monica Stockmann is a Steel Solutions Center advisor, and Thomas J. Schlafly is director of research, both with AISC.*

## Taking the Short Cut—Specifying the Joint Strength

In many cases, an alternative to specifying information in the weld symbol is to specify the required strength of the joint required. The fabricator will then design the weld to develop the strength specified as he or she sees economically fit, while still abiding by the design rules of AWS D1.1. For example, a weld symbol without a dimension and without CJP in its tail designates a weld that will develop the adjacent base metal strength in tension and shear.

### To return or not to return?

End returns, otherwise known as boxing, are the continuation of a fillet weld around the corner of a member as an extension of the primary weld. End returns are used to ensure quality terminations to welds and to provide some resistance to prying of the weld roots. In general, end returns are neither prohibited nor required. AISC specification Section J2.2b provides further discussion on the requirements and limitations for end returns. In statically loaded structures, fillet welds can be stopped short of the end of the joint by a length equal to the leg size of the weld, or continue to the end or be returned around the corner, except as noted in J2.2b(1)-(4). One exception to note is that for flexible connections, such as framing angles and tees, the tension edges of the outstanding legs or flanges must be left unwelded over a portion of their length to assure flexibility of the connection. If end returns are used in this case, their length must be restricted to not more than *four times the weld size or half the width of the angle*, as shown in the following figure.

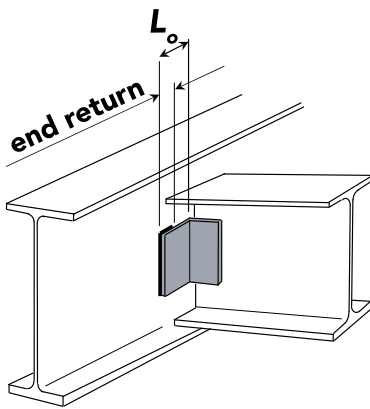

End return length =  $2w$  (preferred), with a maximum of  $4w$  or  $\frac{1}{2}L_o$ , whichever is less.

There is no defined or code-specified standard symbol for welded clip angle connections. Some firms include figures and descriptions of their typical weld practices on the general detail sheet of their shop drawings. Thus, it would be reasonable to include typical weld end condition details on this sheet as well. Some commonly used weld symbols for a returned and a “stopped-short” (non-returned) weld are shown in the figures below. In addition, a commonly used symbol for an angle that is welded on three sides is also shown below. These symbols are not AWS standards; they are simply suggestions.

**Table 3–2. Weld Selection Based on Loading and Joint Type**

Joint Type	Force Type	Loading Level	Normal to the Weld Axis	Parallel to the Weld Axis	Shear
Butt Joints	Tension	Light	PJP	PJP	
		Heavy	CJP	PJP	
	Compression	Light	PJP	PJP	
		Heavy	PJP with bearing considered, CJP	PJP	
	Shear	Light			PJP
		Heavy			CJP
Tee Joints	Tension	Light	Fillet	Fillet	
		Heavy	Fillet, PJP, PJP/Fillet, CJP	Fillet	
	Compression	Light	Fillet	Fillet	
		Heavy	PJP with bearing considered, CJP	Fillet	
	Shear	Light			Fillet
		Heavy			Fillet, PJP, PJP/Fillet, CJP
Corner Joints - Outside	Tension	Light	PJP	PJP	
		Heavy	CJP	PJP	
	Compression	Light	PJP	PJP	
		Heavy	PJP with bearing considered, CJP	PJP	
	Shear	Light			PJP
		Heavy			CJP
Corner Joints - Inside	Tension	Light	Fillet	Fillet	
		Heavy	Fillet, PJP, PJP/Fillet, CJP	Fillet	
	Compression	Light	Fillet	Fillet	
		Heavy	PJP with bearing considered, CJP	Fillet	
	Shear	Light			Fillet
		Heavy			Fillet, PJP, PJP/Fillet, CJP
Lap Joints	Shear	Light			Fillet, Plug/Slot
		Heavy			Fillet, Plug/Slot, Fillet/Plug/Slot

Source: AISC Design Guide 21, *Welded Connections—A Primer for Engineers*

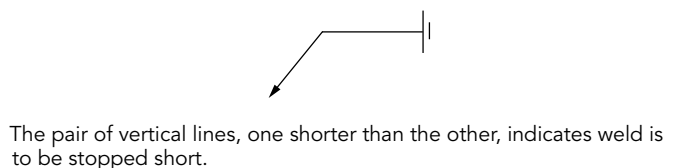
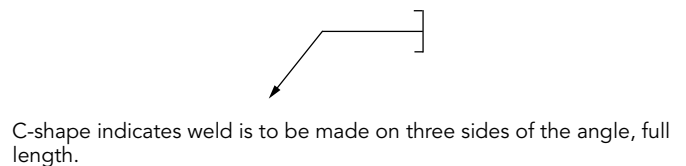
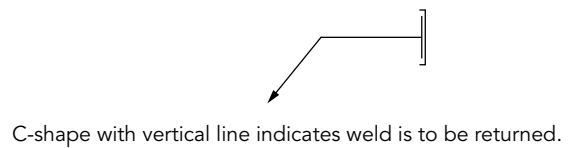

### Why Weld All Around?

The “weld all around” symbol specified by the designer is a convenience that often results in unnecessary work and confusion for the fabricator. The symbol is all too often used in applications where the weld is not necessarily required on the entire perimeter of a connection, such as certain types of column-to-base plate connections. Instruction for the fabricator to weld all around typically requires him to reposition the steel pieces several times, and the process often requires welding in areas that are difficult to access. To avoid specifying a fabrication headache, the engineer should think twice about how much weld is actually needed in the connec-

tion. For a column-to-base plate connection, perhaps a weld along the top of one flange and the bottom of the other flange would suffice—and the fabricator will be able to access the specified weld areas easily, even without having to reposition the members.

### CVN Toughness

Toughness is a material property that measures the resistance to cracking in certain conditions. Charpy V-Notch (CVN) toughness is a test requirement related to material toughness. Some filler metal classifications include CVN requirements. In the U.S., common classifications require a CVN toughness of 20 ft-lb at -20 °F or 0 °F as used in seismic applications. If notch toughness of welded joints is required, the engineer needs to specify the minimum absorbed energy and the corresponding test temperature for the filler metal classification to be used. As an alternative, the engineer needs to specify that the Weld Procedure Specification (WPS) be qualified with CVN tests.

### Weld Design Information

Engineers often provide guidance on

welding in design drawings and specifications in order to prevent misunderstandings and to emphasize code requirements. Although the design professional may intend to avoid past welding conflicts or errors, the welding information provided on their design drawings can often conflict with code requirements and cause unintended confusion.

Most welds performed on structural steel are meant to be conducted in accordance with prequalified weld procedures. The code includes provisions for selection of appropriate welding processes, filler metal classifications, joint designs, procedure variables, and other provisions guiding fabrication. Weld procedures that are not prequalified have to be tested, and the AWS D1.1 limits the essential variables to ranges around those that were tested. Information about these items on design drawings may not be helpful, and in some cases may conflict with good practice. For example, do you really want to specify E70 in cases that AWS D1.1 would indicate an E80 electrode for weathering characteristics?

Chapters 1 and 2 of AWS D1.1 illustrate all of the specific welding requirements that

the engineer shall specify in the contract documents as necessary. Some key things to remember include: *tell* the fabricator what strength you assumed when sizing fillet and pipe welds; *tell* the fabricator to comply with AISC and AWS; and then *check* Chapters 1 and 2 of the AWS code to see if you need to *tell* the fabricator any more.

### Call to Action

Proper weld design and specification results in significant project cost savings. Although many engineers enter the workforce with little or no weld design experience, it is important for them to research, learn, and master welded connection design based on both safety and economy. The best weld detail for a specific connection is one that reliably and safely transmits the imposed loads, and yet is economical and easily made by the welder. Your challenge: put these lessons learned to practice in your everyday design work, and you will surely put a smile on the welder's face during fabrication.

MSC